



Australia's National
Science Agency

Managing Hazardous Areas (HA) Technical Guide

Revision 1.8

07 Feb 2024

Contents

	Managing hazardous areas – Overview and navigating this guide	3
1	Introduction	1
2	Identifying Hazardous Areas.....	2
	2.1 Potentially Explosive Atmospheres	2
	2.2 Ignition Sources	3
	2.3 Elimination of Risk	4
	2.4 Hazardous Zone Classification.....	4
	2.5 Hazardous Area Report	5
3	Managing Hazardous Areas	8
	3.1 Mitigation of Risk.....	8
	3.2 Removal of Ignition Sources.....	8
	3.3 Relocation of Equipment.....	8
	3.4 Hazardous Area Rated Equipment	9
	3.5 Other Risk Controls.....	18
	3.6 Hazardous Area Drawings	19
4	Hazardous Area Verification Dossier	20
5	Maintaining Hazardous Area Equipment	22
	5.1 Documentation.....	22
	5.2 Maintenance & Inspection	22
	5.3 Signage	24
	5.4 Regular Review	24
	Appendix A – Hazardous Area Classification for Potentially Explosive Atmospheres.....	25
	Appendix B – Key Legislation, Codes & Standards.....	27
	Appendix C – Examples	28
	Glossary.....	47

Managing hazardous areas – Overview and navigating this guide

A “hazardous area” (HA) is a location where an explosive atmosphere could develop, whether it be within a process, piece of equipment, apparatus or in a room. Consider: flammable gases, vapours, dusts.

Identify Hazardous Areas

(pg. 2)

i.e. could an explosive atmosphere be present?

You must:

1. **Consult** (pg. 2) – with those familiar with the work.
2. **Locate** (pg. 3) – ignition sources.
3. **Risk Assess** (pg. 3) – likelihood of explosive atmosphere in contact with ignition sources.

If there is a risk of explosion: i.e. an ignition source is in a hazardous area.

1. **Eliminate the risk** (pg. 4). If this cannot be done, then:
2. **Manage HA.** (pg. 8) – see next section.
3. **Develop a HA Report** (pg. Hazardous Area Reports) - where elimination and substitution are not possible.

Manage Hazardous Areas

(pg. 8)

If a hazardous area is identified...

Minimise risk by one or a combination of: (pg. 8)

- **Substituting** the flammable material.
- **Reducing the quantity** of flammables.
- **Isolating** the process from **ignition sources.**
- **Engineering controls.**
- **Administrative controls,** e.g., SOPs.
- Providing **personal protective equipment** (PPE).

If the HA still exists:

1. **Remove ignition sources** (pg. 8) – most effective, least cost.
2. Use **Certified HA Rated Equipment** (pg. 9) – consult licensed electrical inspector with HA qualifications.
3. Ensure **adequate ventilation** (pg. 18)
4. Install **flammable gas detection systems** (pg. 18) – required if the concentration could exceed 5% of the gas’ LEL
5. **Control static electricity** (pg. 19) – consult a specialist.
6. **Create and keep HA drawings** (pg. 19) – available as part of HA dossier.

Develop a Hazardous Area Verification Dossier

(pg. 20)

- Must be kept where HA rated equipment is located.
- This is a “live” document.
- It is a set of documents showing compliance of electrical equipment and installations.
- Produced in consultation with area occupiers and specialists.
- See page 20 of the HA guide for all elements of the dossier.

Maintain Hazardous Area Equipment

(pg. 22) Using the Hazardous Area Dossier.

You must:

1. **Keep records** (pg. 22) – using a HA Verification Dossier.
2. **Engage licensed electrical inspectors with HA qualifications** (pg. 22) – to conduct maintenance and inspections.
3. **Install signage** (pg. 24) – on area hazard posters and within/close to HAs.
4. **Regularly review HA conditions, equipment and maintenance** (pg. 24)

Maintenance work must:

- Use a **Permit to Work system** that includes (pg. 22):
 - **Job Safety Analysis** (JSAs)
 - **Safe Work Method Statement** systems (SWMS)
- **Apply Work Permits to HA equipment maintenance AND general maintenance activities.**

1 Introduction

This document is intended to provide technical guidance for CSIRO employees working in research facilities in Australia, to enable them to identify and manage hazardous area related risks in their operations where flammable materials are used and stored. It includes information that will allow them to determine if electrical installations will require special hazardous area protection and the requirements for maintaining the equipment. Where hazardous areas are identified, additional induction or training may be necessary for staff working in those areas.

The term “hazardous area” refers to locations where a potentially explosive atmosphere may occur, whether it be within a process, piece of equipment, apparatus or in a room.

In this context, the term “hazardous area” **does not** refer to locations where human exposure to hazardous chemicals (e.g., toxic substances) may occur, or where other hazards, such as from slips, trips and falls, may exist.

2 Identifying Hazardous Areas

2.1 Potentially Explosive Atmospheres

2.1.1 Hazard Identification

The first step in identifying a hazardous area is determining if there is likely to be a potentially explosive atmosphere present.

This requires a good knowledge of the process, the equipment or apparatus used, the chemicals used, and the materials produced or generated.

All these factors will help identify where an explosive atmosphere is likely to occur. Some questions to ask are:

- Do the chemicals used in the process give off flammable vapours?
- Are flammable gases used or produced in the process?
- Will powders or dust be released during the process, or are large volumes of powders or dusts stored?
- Will heating be used in the process or will heat be involved or be created during the process?
- Is the apparatus designed to contain the results of the process or will material be released?
- Is the apparatus' materials of construction compatible with the process? Especially worth considering for repurposed equipment.
- If new equipment is used in an experiment, will it be operating within the bounds of the manufacturer's certified operating condition limits?
- Does the process involve the re-use or upscaling of existing apparatus? If so, will the apparatus still be operating within its original safe working conditions, e.g., with respect to pressure and temperature?
- Is any existing or new pipework mechanically jointed (e.g., joined by screwed couplings or flanges) or continuously welded? Has the pipework been pressure tested?
- Does the by-product of the process give off flammable vapours?
- Is there oxygen or other oxidisers present?
- Is the area well ventilated? Is the ventilation appropriate for the size of the area and the materials that are likely to be present?
- What happens if there is an accidental release or spill of material? What likely form will the spill take, e.g., gas, vapour or liquid?

The answers to these and similar questions that are appropriate to the actual process will help identify if there is the potential for an explosive atmosphere to exist.

You may also want to consider using a HAZOP study to identify hazardous areas. This process is best done at the design stage and can be time consuming.

2.1.2 Likelihood of Explosive Atmosphere

The next step would be to assign a probability or likelihood to the various ways an explosive atmosphere may be produced. This will assist with determining if it is necessary to proceed with identifying potential ignition sources or whether, if there is such an extremely low likelihood of an explosive atmosphere occurring, further assessment is not necessary.

This can be done by conducting a risk assessment to establish the frequency of occurrence of the events that may lead to an explosive atmosphere.

This can be based on statistics relating to previous incidents or manufacturer data, if available, and knowledge of the components that make up the process. It may be quantitative or qualitative.

If there is any doubt, or the likelihood is not easily quantifiable, it must be assumed that an explosive atmosphere is likely to be present.

2.2 Ignition Sources

Generally, unless a self-reacting, pyrophoric or other spontaneously combustible substance is involved, there are three conditions necessary for a fire or explosion to occur. A flammable or combustible material must be present; an oxidant (e.g., oxygen) must be present and the resulting mixture must be within the material's flammability or explosive range; and an ignition source must be available to ignite the mixture.

The assessment of the existence of a potentially explosive atmosphere will have established if a flammable or combustible material is present and if a flammable or explosive mixture is likely to occur. The next step is therefore to establish if there is a potential ignition source available to ignite the mixture (e.g., flammable vapour or gas and air; a dust cloud and air).

There are several potential ignition sources that may be present in a laboratory, including:

- Open flames
- Hot surfaces
- Sparking or arcing parts of electrical equipment including electric motors (e.g., vacuum pumps and compressors, refrigerators and freezers), light switches and light fittings
- Mechanical sparking due to friction between parts
- Electrostatic discharge (e.g., due to static charge build-up on clothing).

To achieve ignition of a potentially explosive atmosphere, the ignition source must have sufficient energy to ignite the mixture. There are other factors involved in the process of ignition, but a discussion of these is beyond the scope of this guide.

In most circumstances, ignition sources will be present. If there is potential for an explosive atmosphere to encounter the source of ignition, a risk assessment must be undertaken to establish the level of risk.

If the risk is sufficient to require action, then action must be taken in accordance with the hierarchy of risk controls. That is, in descending order of effectiveness:

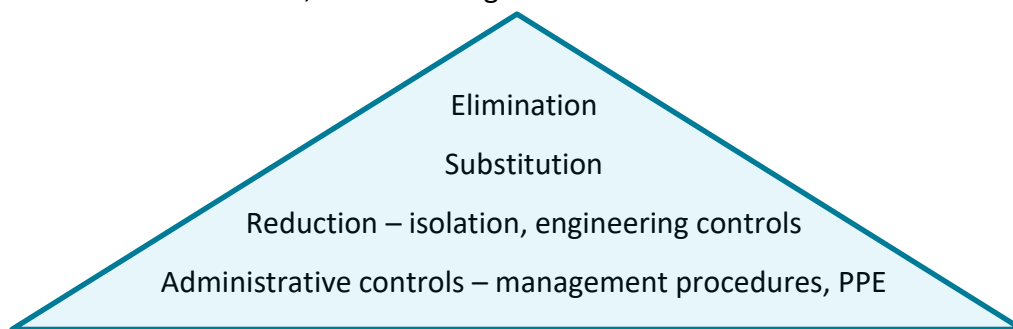

A combination of these risk control methods may be necessary.

2.3 Elimination of Risk

Once a hazardous area has been identified and the level of risk assessed, you must first try to eliminate the risk.

Consider:

- Replacing the flammable materials with non-flammable alternatives,
- Altering the process, preventing a flammable atmosphere occurring, or
- Terminating the process in its current form if the risk is too great.

In most cases it will **not** be possible to eliminate the risk completely using these methods.

An alternative elimination strategy is to relocate all ignition sources outside the hazardous area (See Section 3.2 below for more details). In this case the hazardous area should still be documented for future understanding of where equipment or ignition sources cannot be located. If the risk assessment identifies that elimination controls cannot be used to control the risk, a Hazardous Area Report must be undertaken.

2.4 Hazardous Zone Classification

Hazardous zones for flammable gases and vapours are classified into three levels that are equivalent to the relative level of risk. From higher to lower risk these are: Zone 0, Zone 1 and Zone 2. Simply put, these zones cover a range of likelihoods that there will be an explosive atmosphere present, as follows:

- a. Zone 0 – nearly always present,
- b. Zone 1 – normally present occasionally,
- c. Zone 2 – not normally present, but if it is, for short periods only.

Similarly, for explosive dust atmospheres, the zones are; Zone 20, Zone 21 and Zone 22. Refer to Appendix A for more detail.

Although explosive dust atmospheres may be encountered in laboratory operations, it is far more common that where explosive atmospheres occur, they will be due to flammable gases and vapours.

As such, most of the following discussions and examples will relate directly to the latter. Many of the general considerations, however, will also apply to explosive dust atmospheres.

Where ignition sources cannot be excluded from the hazardous area, the type of Zone applying to a hazardous area will govern the level of explosive (Ex) rating required for the potential ignition source, e.g., electric motors. This Ex rated equipment generally becomes considerably more complicated and expensive as the Zone rating moves higher (i.e., Zone 0 equipment is more expensive than Zone 2 equipment). Refer to Section 3.4 for further discussion of Ex rated equipment.

2.5 Hazardous Area Report

The purpose of a Hazardous Area Report is to document the inputs and outcomes of a hazardous area assessment and provide the basis for the classification of hazardous zones.

Hazardous Area Reports for a particular installation may be developed internally by the organisation only if those involved have the required expertise and understanding of the relevant AS 60079 series. Alternatively, it can be produced by specialists in consultation with the work area users.

An understanding of the process, equipment, materials and location of the works are important considerations. This will assist in identifying the sources of release and extent of the hazardous areas.

An essential part of this process is to identify the properties of the flammable material/s present so the risk level of each material can be assessed. These material properties typically consist of parameters such as ignition temperature, density and lower explosive limits, etc. An example of a data sheet containing flammable material properties is shown in Appendix C of this guide. The group and temperature class of the flammable material is an aid to selecting appropriate hazardous area rated equipment that may be required to operate in these areas.

The outcomes of the hazardous area assessment as documented in the report will be information on the type and extent of the hazardous areas pertaining to the process or facility. This information will consist of the extent and type of hazardous zones (e.g., Zone 1 or Zone 2) in the form of drawings and data sheets. An example of a data sheet containing a list of sources of release and hazardous zones type and extent is shown in Appendix C of this guide.

The extent and type of hazardous zones due to flammable vapours and gases for a number of typical situations are shown in the relevant illustrative examples described in AS/NZS IEC 60079.10.1 Supplement 1: 2022. Where applicable, these illustrative examples can be used to define the hazardous zones for a particular situation (category of occupancy) and will form the basis of the hazardous area documentation. If the actual situation departs significantly from the

typical examples, the type and extent of the hazardous zones must be defined by the fundamental principles as discussed in AS/NZS IEC 60079.10.1. A useful schematic approach to classifying hazardous areas is shown in the form of a flowchart (Annex F) in AS/NZS IEC 60079.10.1.

Below is a typical example of a hazardous area drawing:

Figure 1 – Laboratory hazardous areas – Example from AS/NZS 60079.10.1
Laboratory bench and floor level

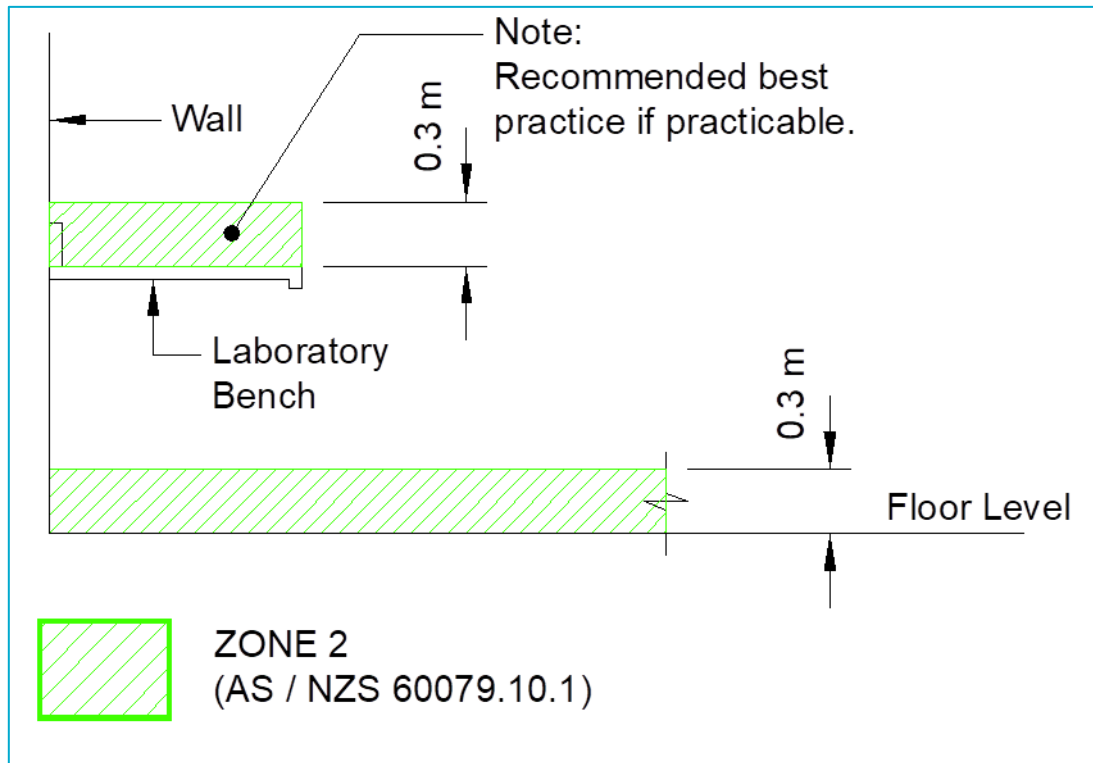

Figure 2 – Fume cupboard hazardous areas – Example from AS/NZS 60079.10.1 Sup. 1
 F.1.3 - Fume cupboard not complying with AS/NZS 2243.8 and laboratory floor level

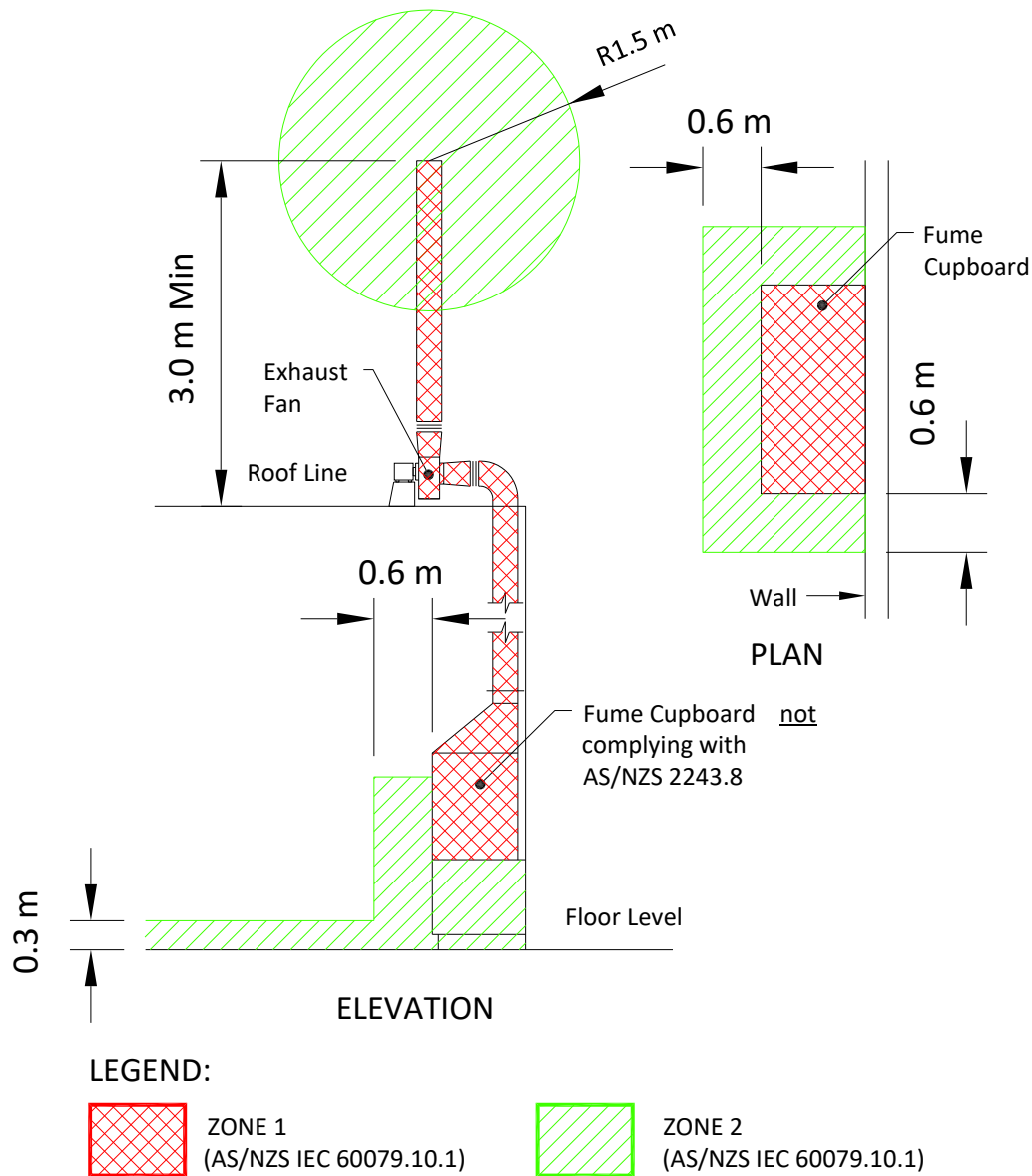

Figure F.1.3

Fume cupboard not complying with AS/NZS 2243.8. Note as of 2021, fume cabinets complying with AS/NZS 2243.8 are not automatically considered hazardous areas.

Hazardous area drawings for installations, in addition to the above figures, will generally include more detailed floor plan layouts, sections and elevations showing the extent and type of zoning based on architectural floor plans of the facility. These may also include detailed zoning in and around apparatus and equipment, as well as around pipe fittings, valves and in pits and conduits. Detailed manufacturer's equipment drawings and mechanical services drawings would normally be required for the latter details.

3 Managing Hazardous Areas

3.1 Mitigation of Risk

Where elimination of risk is not possible, it is necessary to reduce the risk so far as is reasonably practicable. This can be done, for example, by:

- substituting the flammable material with a less flammable material,
- reducing the quantity of flammable materials used,
- isolating the process from personnel and ignition sources,
- applying engineering controls such as local ventilation,
- applying administrative controls such as safe operating procedures and training, and/or
- providing personal protective equipment.

A combination of some or all of these initiatives may be used to reduce the risk when elimination is not possible.

3.2 Removal of Ignition Sources

If the source of release cannot be eliminated and a hazardous area will exist, the most effective ways to manage the risk, with generally least cost, is to ensure that no ignition sources are present within the hazardous area.

This means that all potential ignition sources (e.g., non-rated electrical equipment such as compressor motors, general power outlets (GPOs), etc.) must be located outside of the hazardous area. With a new building design or fit-out this can be achieved by good planning and design. With an existing facility, potential ignition sources will need to be removed (see below).

A very important consideration when controlling the hazardous area risk through the removal of ignition sources is to ensure that strict operating procedures are in place that prevent unrated fixed or portable ignition sources being installed or brought into the hazardous area. These procedures must be communicated to all personnel involved in the laboratory operations, including cleaning staff and contractors.

3.3 Relocation of Equipment

A survey must be undertaken of all equipment in existing facilities that are being converted into one where there is a risk of a hazardous area being introduced. This will require all non-rated ignition sources and equipment to be relocated out of the hazardous area or replaced with hazardous area rated equipment.

3.4 Hazardous Area Rated Equipment

3.4.1 Types of Protection

Multiple explosion protection techniques, or types of protection, are available for hazardous area rated electrical equipment. These techniques are identified by the prefix Ex (meaning *Explosion-protected*) followed by a letter corresponding to the type of protection. The following table summarises the various types of protection grouped by their principal method of protection.

Table 1 – Types of Explosion Protection

Method	Symbol	Type of Protection
Exclusion	Ex t	Dust ignition protection
	Ex m and Ex mD	Encapsulation
	Ex n	Non-sparking (hermetically sealed devices, sealed devices and restricted breathing)
	Ex o	Oil-immersion
	Ex p and Ex pD	Pressurised enclosure
	Ex q	Powder filled (sometimes called 'sand filled')
Explosion containment	Ex d	Flameproof enclosure
	Ex n	Non-sparking (enclosed-break devices)
Energy limitation	Ex i and Ex iD	Intrinsic safety
	Ex n	Non-sparking (non-incendive components and energy limitation)
Dilution	Ex v	Ventilation
Avoidance of ignition source	Ex e	Increased safety
	Ex n	Non-sparking (inherently non-sparking)
Other techniques shown to be suitable by test	Ex s	Special protection

Discussion of the applicability of the various techniques is beyond the scope of this guide, however, for Zone 1 areas the most common protection techniques are Ex d (flameproof) or Ex i (intrinsic safety); and for Zone 2 areas Ex n (non-sparking) is commonly used. Generally, within each Method grouping (e.g., Exclusion), any Type of Protection can be used (e.g., Encapsulation or Pressurised enclosure) to achieve the aim of that method, subject to the limitations of applicability imposed by the specific application. For non-electrical equipment, an Ex h marking will indicate it is suitable for hazardous areas in accordance with the ISO/IEC 80079 series of standards as modified in Australia (AS/NZS 80079 suite).

In addition to the type of protection chosen, other parameters which relate to the selection of electrical equipment for hazardous areas include the apparatus Group and the apparatus Temperature classification. These parameters will be discussed further in Section 3.4.2 below.

Hazardous area rated equipment suitable for a higher risk zone is acceptable for lower risk zones, e.g., Zone 1 rated equipment is suitable for use in a Zone 2 hazardous area. However, the reverse is not true; that is, Zone 2 rated equipment is not suitable for use in a Zone 1 or Zone 0 hazardous area.

When it is not possible to provide suitable hazardous zone rated equipment for certain areas, the method of dilution ventilation control may be used to minimise the possibility of an explosive gas or vapour mixture forming. The methodology used is based on that described in Appendix A of AS 1482¹ “Electrical equipment for explosive atmospheres - Protection by ventilation - Type of protection v”. This methodology provides a means to calculate the rate of dilution air flow required to control the concentration of a vapour or gas emitted into the air to no more than 25% of the vapour or gas’s Lower Explosive Limit (LEL). Another related method is described in Annexe B of AS/NZS 60079.10.1. This calculation procedure assesses the degree and availability of ventilation that will assist in controlling the dispersion and persistence of an explosive gas or vapour atmosphere and it can be used to estimate the extent of the hazardous zones.

3.4.2 Selection of Equipment

The selection of electrical apparatus for use in a hazardous area generally requires the following key information to be considered:

- a. The classification of the area, i.e., Zone 0, 1 or 2. As discussed in Section 2.4.
- b. Where applicable, the Group or the characteristics of the gas or vapour involved in relation to:
 - i. igniting current or minimum ignition energy for installations of intrinsically safe apparatus; or
 - ii. safe gap data in the case of installations for flameproof enclosures.
- c. The temperature class or ignition temperature of the gas or vapour involved.
- d. Other considerations, such as protection from mechanical damage, the relevant ambient temperature, non-electrical ignition sources, the control of static electricity, ingress protection (IP rating), etc. must be taken into account in the apparatus selection process.

The Equipment Grouping (Group) is a classification system of equipment related to the explosive atmosphere for which the equipment is intended to be used. This data is derived from experiments involving the subject gas or vapours. The three Groups are as follows:

- Group I - equipment for mines susceptible to firedamp (a gas that occurs naturally in coal seams and is primarily coalbed methane);
- Group II - equipment for all places with an explosive gas atmosphere other than mines susceptible to fire damp (this Group is divided into three sub-groups; A, B and C);
- Group III - equipment for all places with an explosive dust atmosphere other than mines susceptible to fire damp (this Group is divided into three dust-type sub-groups; A, B and C).

Group II is the group relevant to most laboratory operations involving flammable vapours and gases. Group III applies to combustible dust hazards which may be applicable in some laboratory situations. Group I is generally only relevant to the mining industry.

¹ Note: AS 1482 Appendix A has been incorporated in Appendix H of AS/NZS IEC 60079.10.1 Supplement 1

Equipment belonging to Group II is subdivided according to the nature of the explosive gas atmosphere for which it is intended. Group II subdivisions are as follows:

- IIA, a typical gas is propane
- IIB, a typical gas is ethylene
- IIC, typical gases are hydrogen and acetylene.

The Group subdivisions are based on the Maximum Experimental Safe Gap (MESG) or the Minimum Igniting Current ratio (MIC ratio) of the explosive gas atmosphere in which the equipment may be installed. Either or both of these parameters are used to define the correct subdivision. (For further information on the derivation of the MIC and MESG values and for tabulated data of many gases and vapours, refer to AS/NZS 60079.20.1).

In simple terms of the risk of a gas or vapour being ignited, IIC is a higher risk than IIB, and IIB is a higher risk than IIA. Hence, equipment marked IIB is suitable for applications requiring Group IIA equipment. Similarly, equipment marked IIC is suitable for applications requiring Group IIA or Group IIB equipment. This is shown in the table below.

Table 2 – Allowable Apparatus & Gas Group II Subdivisions

Group of Gas	Allowable Group of Apparatus
IIA	IIA, IIB, IIC
IIB	IIB, IIC
IIC	IIC

The Temperature Class is a classification system of Ex equipment, based on its maximum surface temperature, related to the specific explosive gas atmosphere for which it is intended to be used. This data is again derived from experiments involving the subject gas or vapours. The table below shows the different Temperature Classes in relation to Group II electrical equipment.

Table 3 – Relationship between Temperature Class, Surface Temperature & Ignition Temperature

Temperature Class of Electrical Apparatus	Maximum Surface Temperature of Electrical Apparatus (°C)	Auto Ignition Temperature of Gas Or Vapour (°C)	Allowable Temperature Classes of Equipment
T1	≤ 450	> 450	T1 to T6
T2	≤ 300	> 300	T2 to T6
T3	≤ 200	> 200	T3 to T6
T4	≤ 135	> 135	T4 to T6
T5	≤ 100	> 100	T5 to T6
T6	≤ 85	> 85	T6

When considering the Temperature Class and an item of electrical equipment located in a hazardous area containing a flammable gas or vapour, for auto-ignition to occur, the surface temperature of the equipment needs to be sufficient to cause the gas or vapour to ignite without the presence of a spark or flame. (The mixture of gas or vapour with air would also need to be

between the gas or vapour's lower explosive limit (LEL) & upper explosive limit (UEL)). To prevent ignition due to hot equipment surfaces, the maximum surface temperature of the equipment must be below the auto-ignition temperature of the gas or vapour. For example, propane has an auto-ignition temperature of 450°C. From the table above, the minimum applicable Temperature Class of apparatus would therefore be T2 (300°C). T3 to T6 rated apparatus would also be suitable for use with this gas. For another example, diethyl ether has an auto-ignition temperature of 175°C. The minimum applicable temperature class of apparatus would therefore be T4 (135°C). T5 to T6 rated apparatus would also be suitable for use with this vapour.

The Temperature Class rating of the hazardous area equipment always corresponds with a temperature less than the auto-ignition temperature of the gas or vapour for which it is intended to be used.

The above Zone, Group and Temperature Class information will be marked on the hazardous area apparatus and the related certification documents.

An alternative (risk-based) designation system for equipment suitable for installation in explosive atmospheres is the Equipment Protection Level (EPL) system. The EPL will sometimes be listed on equipment certificates and markings. The relationship between hazardous zones and EPLs for explosive gas (G) and dust (D) atmospheres are shown in the table below.

Table 4 – Equipment Protection Levels & Hazardous Zone Assignments

Zone	Equipment Protection Level (EPL)
0	Ga
1	Ga or Gb
2	Ga, Gb or Gc
20	Da
21	Da or Db
22	Da, Db or Dc

3.4.3 Interpretation of Equipment Ex Markings

All hazardous area electrical equipment must be appropriately labelled with markings defining the hazardous area/s where the equipment can be safely used, as well as other identifying information. The marking shall include the following:

- a. the name of the manufacturer or its registered trademark
- b. the manufacturer's type identification
- c. a serial number
- d. the name or mark of the certificate issuer and the certificate reference
- e. any specific conditions of use
- f. the specific Ex marking for explosive gas (refer to Table 5 below) or dust atmospheres
- g. any additional marking prescribed in the specific standards for the types of protection concerned.

Table 5 – Summary of Required Equipment (Group II) Marking for Common Techniques

Manufacturer's name or trademark							
Manufacturer's identification/model number							
The following symbols:							
Explosion protection symbol	Type of protection	Apparatus group (or specific gas)	Temperature class (or actual temperature)	Degree of ingress protection (where applicable)			
				Code	1 st Numeral	2 nd Numeral	
Ex	d	IIA	T1	IP	1	1	
	e	IIB	T2		2	2	
	ia or (ia)	IIC	T3		3	3	
	ib or (ib)		T4		4	4	
	ic or (ic)		T5		5	5	
	m		T6		6	6	
	n						7
	o						8
	p						
	q						
	s						
v							

The following figures show typical markings on hazardous area rated equipment.

Figure 3 – Example of a Hazardous Area Rated Equipment Markings – Example 1 - Switch



Example 1: The markings relevant to an Australian context are the IECEx (see Section 3.4.4 below) text. This includes the following information:

“IECEX PTB 06 0090”	This is the Certificate of Conformity number which certifies the equipment as complying with the IECEx Scheme.
“Ex de IIC T6 Gb”	This is the explosive <u>gas</u> atmosphere the apparatus is rated to operate within. Ex de indicates the type of protection is a combination of Flameproof (d) and Increased Safety (e). The Gas Group is IIC and the Temperature Class is T6. The EPL is Gb. Generally, this means that the apparatus is suitable for installation in a Zone 1 or Zone 2 hazardous area that may contain, for example, hydrogen (IIC, T1 gas group).
“Ex tD A21 IP66 T80°C Db”	This is the explosive <u>dust</u> atmosphere the apparatus is rated to operate within. Ex tD indicates the type of protection is by Enclosure. A21 indicates that the Type of Practice is A (A or B, refer to AS/NZS 61241.1:2005 ² <i>Electrical apparatus for use in the presence of combustible dust Part 1: Protection by enclosures ‘tD’</i>) and the explosive dust Hazardous Zone is 21. IP66 is the Ingress Protection rating (first 6 = <i>complete protection against entry of dust</i> ; second 6 = <i>protection against a strong jet of water from all practicable directions</i>). T80°C indicates that the maximum surface temperature of the apparatus is 80°C. The EPL is Db.
“Ta = -20°C ... +55°C”	This is the temperature range the apparatus can operate within.

² Now obsolete. Refer to AS/NZS 60079.31:2014. (tD protection is more recently known as ta, tb or tc).

Figure 4 – Example of a Hazardous Area Rated Equipment Markings – Example 2 - Aspirating Smoke Detector

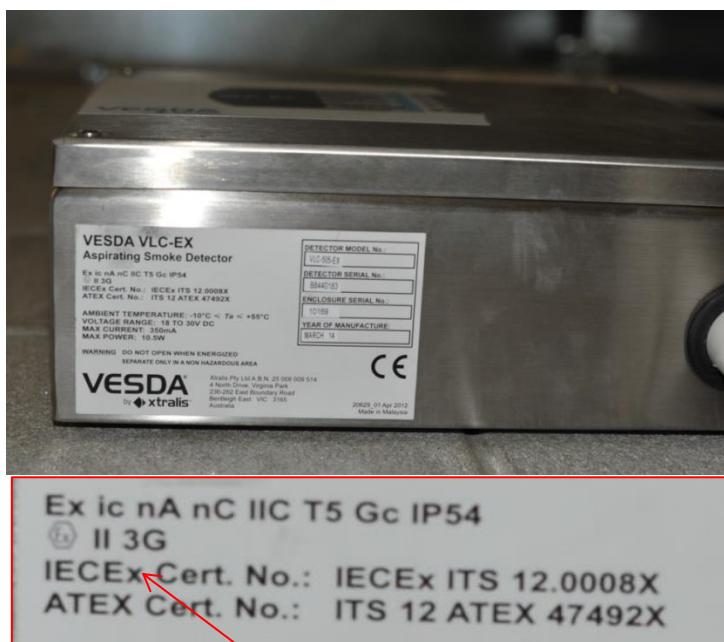

Example 2: The IEC Ex text includes the following information:

“Ex ic nA IIC T5 Gc IP54” This is the explosive gas atmosphere the apparatus is rated to operate within. Ex ic and nA indicates the type of protection is both Intrinsically Safe (ic) and Spark Proof (nA). The Gas Group is IIC and the Temperature Class is T5. The EPL is Gc. IP54 is the Ingress Protection rating. Generally, this means that the apparatus is suitable for installation only in a Zone 2 hazardous area that may contain, for example, acetylene (IIC, T2 gas group).

“IECEX ITS 12.0008X” This is the Certificate of Conformity number which certifies the equipment as complying with the IECEx Scheme.

Where “X” appears in the Certificate of Conformity number, it indicates that the equipment has a *specific condition* of use associated with it and caution must be observed in ensuring the equipment is only used within the limitations of the conditions of use stated in the Certificate of Conformity documents.

3.4.4 Certification of Equipment

All electrical equipment or apparatus that will be installed or brought into a hazardous area must be appropriately hazardous area rated for operation in the particular hazardous zone in which it will be located. To ensure equipment complies with this requirement, it must be tested and certified to operate in the proposed environment. A Certificate of Conformity must accompany all such equipment and it must be marked with the appropriate information indicating the limitations of its use.

In Australia, the International Electrotechnical Commission (IEC) Ex Scheme has largely been adopted for the certification of equipment for explosive atmospheres. Local certification is administered by the Australian National Ex Certification Scheme (ANZEx Scheme). Under this scheme: *the installation standards for electrical equipment to be installed in a Hazardous Area require 'Proof of Compliance' according to a Type 5³ scheme in AS/NZS [ISO/IEC]17067 and the related Standards. **Either a Certificate of Conformity within this ANZEx Scheme or an IECEx Certificate of Conformity is deemed to comply with this requirement.*** The Australian Standards covering explosive atmospheres are now largely based on the equivalent IEC Standards.

In the European Union (EU) an alternative certification scheme is the ATEX scheme. The ATEX scheme operates under two EU Directives and uses European (EN) Standards. While the IECEx scheme is applicable internationally, the ATEX scheme is limited to the EU. Although there are some small differences between each certification, ATEX and IECEx are very similar. In Australia, however, equipment that carries only an ATEX certification is not accepted and would require approval for its use from the appropriate regulatory authority in each state. Other international certification schemes, e.g., from the USA (UL and FM) or Canada (CSA), are generally not accepted in Australia. A Conformity Assessment Document is required for all equipment that does not have an ANZEx or IECEx certification to provide justification for its use and to establish that the equipment protection provides an *equivalent level of safety*.

An example of a typical certificate for a luminaire assembly is shown in the figure below. This is an extract from the full certificate which also includes other pages of supporting information, for example: references to test reports, compliance standards, drawings, operating conditions, etc.

³ The ANZEx and IECEx Schemes are both ISO Type 5 Schemes which involve three basic elements: Type Test, Quality Assurance and Ongoing Surveillance of manufacturers.

Figure 5 – Example of a Certificate of Conformity for a Luminaire

4 0 0 1 . 1



IECEx Certificate of Conformity

INTERNATIONAL ELECTROTECHNICAL COMMISSION
IEC Certification Scheme for Explosive Atmospheres
 for rules and details of the IECEx Scheme visit www.iecex.com

Certificate No.: IECEx CES 07.0001	Issue No.: 2	Certificate history: Issue No. 2 (2015-5-4) Issue No. 1 (2013-9-30) Issue No. 0 (2007-1-18)
Status: Current	Page 1 of 4	
Date of Issue: 2015-05-04		

Applicant: CORTEM S.p.A.
 Via Aquileia 10,
 I - 34070 Villesse (Gorizia)
 Italy

Electrical Apparatus: Luminaries, series EXEL.
Optional accessory:

Type of Protection: Increased safety 'e'; Flameproof enclosures 'd'; Encapsulation 'm'; Dust ignition protection 't'

Marking: Ex de mb IIC T4 Gb or
 Ex de IIC T4 Gb and
 Ex tb IIC T70°C Db or
 Ex tb IIC T80°C Db
 IP66

Approved for issue on behalf of the IECEx Certification Body: Mirko Balaz

Position: Head of IECEx CB

Signature: (for printed version) *Mirko Balaz*

Date: 4-5-2015

1. This certificate and schedule may only be reproduced in full.
2. This certificate is not transferable and remains the property of the issuing body.
3. The Status and authenticity of this certificate may be verified by visiting the IECEx Website.

Certificate issued by:
 CESI
 Centro Elettrotecnico
 Sperimentale Italiano S.p.A.
 Via Rubattino 54
 20134 Milano
 Italy

CESI CEST S.p.A.
 Testing & Certification Division
 Business Area Certification
 Il Responsabile
 (Roberto Piccin)

PAD B5012425 (2098616) - USO RISERVATO

EXAMPLE ONLY

ge

3.4.5 Inspection

All new hazardous area rated equipment installed in a workplace requires an initial inspection by qualified personnel prior to commissioning and use. This is required to ensure that the selected type of protection and its installation are appropriate. The initial inspection is required to be carried out in accordance with the requirements for detailed inspections in AS/NZS 60079.14.

Under all state and territory legislation, electrical equipment installed in a hazardous area is considered to be *prescribed electrical installation work*. As such, the equipment must be inspected by a licensed electrical inspector who has the required level of competency with respect to a detailed understanding of safety in electrical installations in hazardous areas. A Certificate of Electrical Safety issued for the installation must include the details of the inspection of all hazardous area electrical equipment relating to the installation.

For ongoing maintenance and inspection requirements refer to the discussion in Section 5.2.

3.5 Other Risk Controls

3.5.1 Adequate Ventilation

Adequate ventilation as defined by the various codes and standards is a fundamental engineering control for laboratory facilities and must be provided to a laboratory at all times the facility is occupied and operated.

Adequate ventilation is an important component in the prevention and control of hazardous areas since diluting flammable gases and vapours to concentrations below their explosive limits when mixed with air is a very effective risk management control.

In laboratories and hazardous chemical stores, mechanical ventilation is usually relied upon to provide adequate ventilation. Alarms and interlocks should be provided to ensure the laboratories are not operated during periods when the ventilation system is not operational as per the intended design. Consideration should be given to providing the mechanical ventilation system with an emergency power provision to maintain adequate ventilation to laboratory areas.

Natural ventilation may be provided to provide adequate ventilation in some situations; however, these situations are usually limited to outdoor locations or separate stores buildings that have an abundance of high and low ventilation openings (e.g., air louvres and vents).

3.5.2 Flammable Vapour/Gas Detection

A method of providing early warning of the dangerous build-up of flammable vapours or a flammable gas leak in an enclosure is to provide flammable gas/vapour sensors linked to audible and visible alarms.

If it is determined that there is a risk that the concentration of flammable gas could exceed 5% of the gas' LEL, these detection systems must be installed and be interlocked with gas shut-off devices (solenoid valves) and a method of isolating the electrical supply. See the Reticulated Gas Installations and Maintenance Guide for more information.

The mounting height of these sensors will depend on the density of the flammable vapour or gas. Most flammable liquid vapours are heavier than air and a sensor mounted near the floor would be

appropriate. Lighter than air flammable gases such as hydrogen would require a sensor mounted near the highest internal points of the enclosure.

Gas sensors for Flammable Gas/Vapour sensing must be designed in accordance with AS/NZS 60079.29.2:2009 “Electrical apparatus for explosive gas atmospheres: Part 29.2: Gas detectors - Selection, installation, use and maintenance of detectors for flammable gases and oxygen”.

3.5.3 Control of Static Electricity

Where practices in the facility may involve the use or generation of flammable vapours, gases or combustible dusts and there is a risk of spark ignition due to an electro-static discharge causing a fire or explosion, static electricity may be controlled in accordance with the equipotential bonding and earthing requirements of AS/NZS 1020 – “The control of undesirable static electricity” and Clause 9.2.7.4 of AS 1940. A personnel earth bonding method to avoid static electricity may be applicable. The method may consist of an anti-static earthed wrist strap and flexible lead, and may be supplemented by earthed anti-static bench covers, floor mats, chair covers, humidity control and ionized air sources.

The control and management of static electricity is often a complex subject and specialist consultants and electrical engineers may be required to assist with the provision of appropriate techniques depending on the complexity of the situation.

3.6 Hazardous Area Drawings

Hazardous area drawings for the facility that show the extent and type of zoning must be kept by the facility management to inform the laboratory users of the risks associated with each process.

These drawings must be readily available as separate documents or as part of the Hazardous Area Report and the Hazardous Area Verification Dossier (see section 4 of this guide) relating to the facility. A management process must be in place to communicate to all laboratory users, both existing and new, that the area they will be working in is subject to a hazardous area risk management process.

The drawings must be kept up to date to reflect any changes in equipment, processes or materials used.

Examples of typical hazardous area drawings are included in Appendix C of this guide.

4 Hazardous Area Verification Dossier

A Hazardous Area Verification Dossier must be kept at each facility where Hazardous Area rated equipment is located.

A Hazardous Area Verification Dossier (Dossier) is a set of documents showing the compliance of electrical equipment and installations. The production of the Dossier will normally require the help of specialists in consultation with the occupiers of the facility.

A Dossier must contain:

- Hazardous area classification documents (e.g., a Hazardous Area Report), with drawings showing the classification (zones) and extent of the hazardous areas. Include details of any hazard identification and operability analyses and risk assessments.
- As installed, drawings of hazardous area equipment.
- Details of the method of assessment, including any relevant calculations.
- The applicable equipment group or subgroup for the flammable or combustible material.
- The temperature class or ignition temperature of the flammable material.
- Safety Data Sheets for the flammable or combustible material.
- Instructions for erection and connection of hazardous area rated equipment.
- Certificates of Conformity (including conditions of use) for all hazardous area rated equipment, electrical accessories, electrical conduit and connections installed in the hazardous zones.
- Descriptive system documents for any intrinsically safe systems. The document shall specify the items of electrical equipment and the electrical parameters of the system, including those of interconnecting wiring. (Refer to AS/NZS 60079.25 for detailed requirements).
- Details of any uncertified apparatus including manufacturer's name, its type number and the justification for its use. Include Conformity Assessment Documents for all equipment that does not have an ANZEx or IECEx certification.
- Manufacturer's instructions for the equipment, e.g., Operation and Maintenance manuals.
- Information necessary for inspection and maintenance, e.g., schedules, checklists, list and location of equipment, spares, technical information and manufacturer's maintenance instructions.
- Information necessary for the repair of the electrical equipment.
- Records of selection criteria for cable entry systems.
- Drawings and schedules relating to circuit identification.
- Copies of inspection records including details of the initial inspection and all subsequent inspections.
- Copies of defect reports and corrective actions undertaken.
- Copies of maintenance records.

- Any other material that is relevant to the hazardous area classification and the selection, inspection, maintenance and repair of the hazardous area rated equipment.

Further information describing what is expected to be included in a Dossier is contained in Australian Standards AS/NZS 60079.14:2009 and AS/NZS 60079.17:2009.

The Dossier is a “live” document and the details of any alterations to the facility which effect the hazardous areas defined therein, or the hazardous area rated equipment used in those areas, must be incorporated in the Dossier by way of updating the document in a timely manner.

The sole responsibility for updating the document shall rest with the occupier or the authorised representative/s of the facility, or the person conducting the business or undertaking. A copy of an up-to-date Dossier must be kept on the premises at all times, and made available to the personnel who will be working in the hazardous area, and to all maintenance and electrical contractors who will be undertaking work in, or associated with, the hazardous area.

5 Maintaining Hazardous Area Equipment

5.1 Documentation

The minimum documentation required to maintain hazardous area equipment is that contained in the Hazardous Area Verification Dossier. Refer to Section 4 above for the general requirements.

Different hazardous area protection concepts have different maintenance requirements, and it is imperative that the details of the protection techniques used for all the equipment is well documented.

A continuous record of all inspections, defects, repairs and maintenance activities shall be kept and included in the Dossier. Sample maintenance and repair certificates and forms are included in Appendix C of the Standards Australia Handbook HB 239.

5.2 Maintenance & Inspection

Ongoing inspection, testing and maintenance are essential to ensure the continued satisfactory performance and safety of the hazardous area rated equipment and systems.

The inspection and maintenance of hazardous area installations shall be carried out only by experienced personnel with the necessary level of competency, whose training has included instruction about the various types of protection and installation practices, the requirements of the relevant standards and regulations applicable to the installation and the general principles of hazardous area classification.

In general, this will require an external qualified person⁴ to undertake inspection or maintenance of equipment rated for use in hazardous areas.

The following types and levels of inspections shall be undertaken throughout the life of the hazardous area equipment, as appropriate to the type and complexity of the installed equipment, the standard's provisions and the manufacturer's requirements. The frequency of inspections will vary with the type of equipment and should be based on the manufacturer's recommended inspection and maintenance intervals, as well as specific requirements of the installation and good maintenance practice.

Types of inspections:

- a. Initial inspections used to check that the selected type of protection and its installation are appropriate. The initial inspection shall be in accordance with the requirements for detailed inspections in AS/NZS 60079.14.

⁴ Qualified person as per clause 4.2 of AS 60079.17 – 2017. The person may also need to demonstrate the relevant qualifications as required by the local state electrical safety regulator.

- b. Periodic inspections which may be visual, close or detailed in accordance with AS/NZS 60079.17.
- c. Sample inspections which may be visual, close or detailed in accordance with AS/NZS 60079.17. Sample inspections should not be expected to reveal faults of a random nature, such as loose connections, but should be used to monitor the effects of environmental conditions, vibration, inherent design weakness, etc.

Three levels of inspection:

- a. visual inspection - inspection which identifies, without the use of access equipment or tools, those defects, such as missing bolts, which will be apparent to the naked eye.
- b. close inspection - inspection which encompasses those aspects covered by a visual inspection and, in addition, identifies those defects, such as loose bolts, which will be apparent only by the use of access equipment.
- c. detailed inspection - inspection which encompasses those aspects covered by a close inspection and, in addition, identifies those defects, such as loose terminations, which will only be apparent by opening the enclosure, and/or using, where necessary, tools and test equipment.

If any faults or defects are identified during the inspections, it shall be immediately brought to the attention of the responsible person or persons managing the facility. All faults or defects that may compromise the performance of the hazardous area equipment and the safety of the facility shall require the immediate cessation of the activities in the area that may lead to an explosive atmosphere forming. The fault or defect shall be fully rectified before the hazardous area operation can recommence.

Faulty or defective hazardous area rated equipment shall be repaired or replaced as necessary. Where the repairs involve hazardous area rated electrical equipment, they shall be undertaken only by a hazardous area qualified electrician with the required level of competency and may require inspection by a licensed electrical inspector.

A Permit to Work system (e.g., hot works permit), Job safety Analysis and Safe Work Method Statement systems must be employed for all maintenance work carried out in the hazardous area to ensure that maintenance personnel are aware of the risks and importance of not compromising the safety of the hazardous area during the works. This applies to both work related to the hazardous area equipment, and to general maintenance activities. No unauthorised modification shall be made to any apparatus installed in a hazardous area.

Repair and overhaul of Ex rated equipment shall comply with the relevant requirements of AS/NZS 3800 - *Electrical equipment for explosive atmospheres - Repair and overhaul (IEC 60079-19:2015 (ED. 3.1), MOD)*. Further guidance is provided in Standards Australia Handbook HB 239 - *Guidance on the repair and overhaul of electrical equipment for explosive atmospheres*.

5.3 Signage

In addition to the mandatory labelling of all hazardous area rated equipment installed in the facility (refer to Section 3.4.3 above), signage must be provided within or close to the identified hazardous areas. This signage must alert occupants to the presence of a hazardous area due to a potentially explosive atmosphere. The signage may also indicate the type of hazardous zone/s present and should refer to the location of the Hazardous Area Verification Dossier and contact details of a responsible person. A suggested hazardous area sign is as follows:

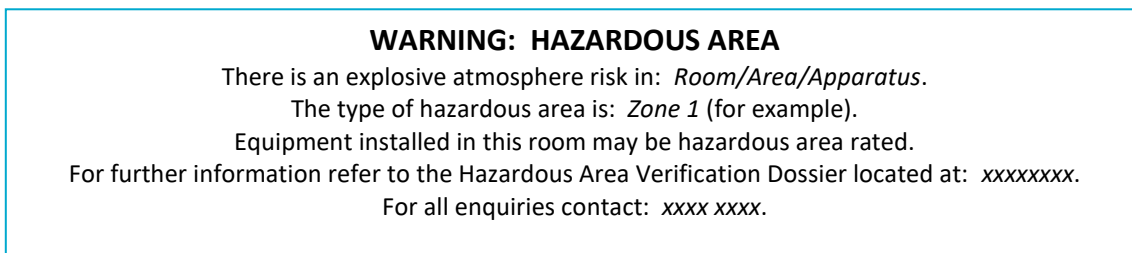

This signage can be incorporated into other room signage indicating hazards in the area. See Appendix C Figure 9 for an example of how the hazardous area signage could be incorporated with a CSIRO area hazard poster template.

5.4 Regular Review

The inspection, testing and maintenance of hazardous area equipment in a facility will require regular review to capture any changes to the operations, materials, condition of equipment or the types of equipment installed. These regular reviews and upkeep of the Hazardous Area Verification Dossier for the facility should form part of the ongoing management (e.g., an area housekeeping inspection).

Appendix A – Hazardous Area Classification for Potentially Explosive Atmospheres

Background

A hazardous area can be defined as an area in which an explosive atmosphere (due to flammable gas, vapour or combustible dust) is present, or may be expected to be present, in quantities such as to require special precautions for the construction, installation and use of apparatus.

Hazardous area classification is a method of analysing and classifying the location where explosive atmospheres may exist. From this the facility management team can implement appropriate control procedures. One of these is the proper selection and installation of electrical apparatus for that location.

The hazard can be due to flammable liquids, vapours, mists, gases, combustible dusts, fibres or flyings (waste fibres generated through carding, drawing, spinning or similar).

Workplace safety and dangerous goods storage and handling legislation requires a hazardous area classification assessment to be carried out where workplace hazards involve the risk of explosion due to gases and vapours and dusts. The 'area classification' must be carried out before any apparatus can be installed.

The nature of the hazard, in particular the relevant properties of the hazardous material, must be considered as part of the analysis. For gases, vapours, mists and flammable liquids the area classification establishes the zone, gas classification, temperature classification, the extremes of ambient temperature that may be encountered and any specific requirements of the location.

Zone Classifications

AS/NZS 60079.10.1 defines three zones for flammable vapours and gases as follows:

Zone 0 – an area in which an explosive gas atmosphere is present continuously or is present for long periods or frequently. Examples would be the vapour space of vented vessels, vapour space of vented storage tanks and immediately adjacent to a continuous source of release.

Zone 1 – an area in which an explosive gas atmosphere is likely to occur in normal operation occasionally. Examples would be where pumps are liable to leak under normal conditions, or where vents, relief valves or sample points are likely to release vapour to the atmosphere.

Zone 2 – an area in which an explosive gas atmosphere is not likely to occur in normal operation but, if it does occur, it will exist for a short period only. Examples would be where vessels, pumps, compressors and pipes containing flammable gases and liquids are constructed and maintained to prevent leakage under normal operating conditions.

The preferred symbols for hazardous zones relating to flammable vapours and gases that would be displayed on hazardous area diagrams or drawings are shown in Figure 6 below. Different symbols are used for explosive dust atmospheres (refer to AS/NZS 60079.10.2 Clause 8.2.2, Figure 1).

Figure 6 – Symbols for Flammable Gas or Vapour Hazardous Area Zones as per AS/NZS 60079.10.1:2009

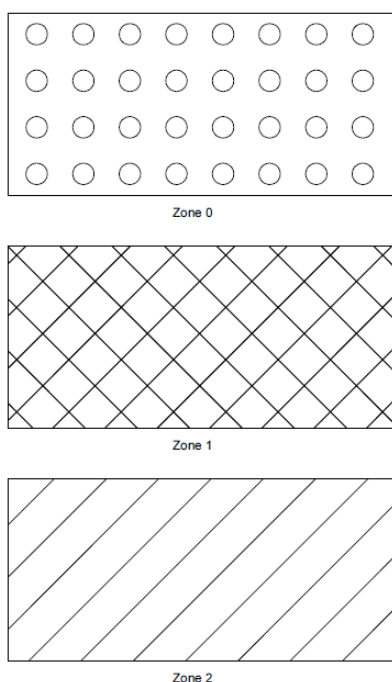

AS/NZS 60079.10.2 similarly, but with some differences due to the nature of the material, defines three zones where explosive dust atmospheres may exist (defined as Zones 20, 21 and 22). These zones are defined as follows:

Zone 20 – a place in which an explosive dust atmosphere, in the form of a cloud of dust in air, is present continuously, or for long periods or frequently. The dust will be in sufficient quantity to be capable of producing an explosive concentration of combustible dust mixed with air, and/or where layers of dust of uncontrollable and excessive thickness can be formed. Examples include dust containment areas where dust can form explosive mixtures frequently or for long periods of time. This occurs typically inside apparatus.

Zone 21 – a place in which an explosive dust atmosphere, in the form of a cloud of dust in air, is likely to occur in normal operation occasionally. The dust will be in sufficient quantities to be capable of producing an explosive concentration of combustible dust mixed with air. Examples include areas in the immediate vicinity of powder filling or emptying points and areas where dust layers occur and are likely in normal operations to give rise to an explosive concentration of combustible dust mixed with air.

Zone 22 – an area in which an explosive dust atmosphere, in the form of a cloud of combustible dust in air, is not likely to occur in normal operation but, if it does occur, will persist for a short period only. This may also occur when accumulations or layers of combustible dust may be present under abnormal conditions and give rise to combustible mixtures of dust in air. Examples include, amongst others, areas in the vicinity of apparatus containing dust in which dust can escape from leaks and form deposits (such as milling rooms in which dust can escape from the mills and then settle).

Appendix B – Key Legislation, Codes & Standards

- Commonwealth Work Health and Safety Act 2011 and Regulations 2011.
- Managing Risks of Hazardous Chemicals in the Workplace - Code of Practice – Safe Work Australia.
- State and Territory Work Health and Safety (or Occupational Health and Safety etc.) Acts and Regulations.
- State and Territory Dangerous Goods (or Hazardous Chemicals etc.) – Storage and Handling Acts and Regulations.
- National Construction Code – Building Code of Australia Volume 1.
- AS/NZS 1020: 1995 – The control of undesirable static electricity.
- AS 1482: 1985 – Electrical equipment for explosive atmospheres – Protection by ventilation - Type of protection v.
- AS 1940: 2017 – The storage and handling of flammable and combustible liquids.
- AS/NZS 2243 Series – Safety in laboratories.
- AS/NZS 2982:2010 – Laboratory design and construction.
- AS/NZS 3800 – Electrical equipment for explosive atmospheres – Repair and overhaul (IEC 60079-19:2015 (ED. 3.1), MOD).
- AS 4332:2004 – The storage and handling of gases in cylinders.
- AS/NZS 4745:2012 – Code of practice for handling combustible dusts.
- AS/NZS IEC 60079.10.1:2022 – Explosive gas atmospheres: Classification of areas – explosive gas atmospheres.
- AS/NZS IEC 60079.10.1:2022 Sup 1: 2022 - Explosive gas atmospheres: Classification of areas – explosive gas atmospheres – Commentary (Supplement 1 to AS/NZS IEC 60079.10.1:2022).
- AS/NZS 60079.10.2:2016 – Explosive gas atmospheres: Classification of areas – explosive dust atmospheres.
- AS/NZS 60079.14:2017 – Explosive atmospheres: Design selection, erection and initial inspection (IEC 60079-14:2013 (ED.5.0) MOD).
- AS/NZS 60079.17:2017 – Explosive atmospheres: Electrical installations inspection and maintenance (IEC 60079-17:2013 (ED.5.0) MOD).
- AS/NZS 60079.20.1:2012 – Explosive atmospheres: Material characteristics for gas and vapour classification – Test methods and data.
- AS/NZS 60079.29.2:2009 – Electrical apparatus for explosive gas atmospheres: Gas detectors – Selection, installation, use and maintenance of detectors for flammable gases and oxygen.
- HB 13—2007 – Handbook – Electrical equipment for hazardous areas.
- HB 239 – 2011 – Handbook – Guidance on the repair and overhaul of electrical equipment for explosive atmospheres.
- <https://www.iecex-certs.com/#/home> -database of certification documentation

Appendix C – Examples

Table C.1 – Hazardous area classification data sheet – Part I: Flammable material list and characteristics.

Table C.2 – Hazardous area classification data sheet – Part II: List of sources of release.

Figure 7 – Examples of typical Hazardous Area Drawings.

Figure 8 – Closed vessel hazardous areas – Example Fig. D.4.2.2 from AS/NZS 60079.10.1 Supp. 1.

Figure 9 – Example of a CSIRO Area Hazard Poster containing the hazardous area signage.

Example of Hazardous Area Risk Assessment – Chemical Storage Cabinets

Table C.1 – EXAMPLE of Hazardous area classification data sheet – Part I: Flammable material list and characteristics

Sheet: 1/1

Plant: Flammable liquid & gas process plant														Reference drawings: Haz. Area Zone Diag.
1	2	3	4	5	6	7	8	9	10	11	12	13	14	15
	Flammable material		Flash-point °C	LEL		Volatility ^a			Polytropic index of adiabatic expansion γ	Relative density gas/air	Ignition temp. °C	Group	Temp. class	Any other relevant information and remarks
No.	Name	Composition		kg/m ³	vol. %	Vapour pressure 20 °C kPa	Melting point °C	Boiling point °C						
1	Ethanol	C ₂ H ₆ O	12	0.060	3.1	5.950	-114	78	n/a	1.600	400	IIB	T2	
2	Methanol	CH ₄ O	9	0.080	6.0	13.020	-98	65	n/a	1.113	440	IIA	T2	
3	Isopropanol	C ₃ H ₈ O	12	0.050	2.0	4.320	-88	83	n/a	2.087	399	IIA	T2	
4	Acetone	C ₃ H ₆ O	-20	0.061	2.5	24.530	-95	56	n/a	2.017	539	IIA	T1	
5	Ethyl acetate	C ₄ H ₈ O ₂	-4	0.073	2.0	9.700	-83	77	n/a	3.059	470	IIA	T1	
6	Toluene	C ₇ H ₈	4	0.038	1.0	2.800	-95	111	n/a	3.199	530	IIA	T1	
7	Xylene	C ₈ H ₁₀	25	0.044	1.0	2.400	-48	139	n/a	3.686	465	IIA	T1	M-Xylene
8	Acetonitrile	C ₂ H ₃ N	2	0.051	3.0	9.864	-45	82	n/a	1.425	523	IIA	T1	
9	MEK	C ₄ H ₈ O	-10	0.045	1.5	9.500	-86	80	n/a	2.504	404	IIB	T2	Methyl ethyl ketone
10	MIBK	C ₆ H ₁₂ O	16	0.050	1.2	2.000	-80	116	n/a	3.478	475	IIA	T1	Methyl isobutyl ketone
11	THF	C ₄ H ₈ O	-14	0.045	1.5	17.000	-108	64	n/a	2.504	230	IIB	T3	Tetrahydrofuran
12	MTBE	C ₅ H ₁₂ O	-27	0.055	1.5	27.900	-109	55	n/a	3.061	385	IIA	T2	Methyl tert-butylether
13	DMF	C ₃ H ₇ NO	58	0.055	1.8	0.360	-61	153	n/a	2.538	440	IIA	T2	N,N-Dimethyl formamide
14	Hydrogen	H ₂	gas	0.003	4.0	gas	-259	-253	1.405	0.070	560	IIC	T1	

^a Normally, the value of vapour pressure is given, but in the absence of that, boiling point can be used (4.4.1d).

Table C.2 – EXAMPLE of Hazardous area classification data sheet – Part II: List of sources of release

Sheet: 1/1

Plant: Flammable liquid & gas process plant Area: Reactor Rooms, Ventilated Cabinets, General Laboratory, Exhaust Fan Room. Chemical Store. DGs Spill Containment Tank.													Reference drawings: Hazardous Area Zone Diagrams		
1	2	3	4	5	6	7	8			9	10	11	12	13	
Source of release			Flammable material				Hazardous area								
No.	Description	Location	Grade of release ^a	Reference ^b	Operating temperature and pressure ^[1]		State ^c	Ventilation			Zone type 0-1-2	Zone extent m		Reference	Any other relevant information and remarks
					°C	kPa		Type ^d	Degree ^e	Availability ^e		Vertical	Horizontal		
1	Flow Reactors	Reactor Rooms 1, 2 & 3	S	1 - 13	220	4200	L	A	Medium	Good	2	0.3*	**	SK01, SK05 & SK06	*Above floor & below ceiling. **Extent of room. Outside Zone - Protection by ventilation, Type v.
2	Flow Reactors	Reactor Rooms 1, 2 & 3	S	14	25	3000	G	A	Medium	Good	2	0.3*	**	SK01, SK05 & SK06	*Below ceiling. **Extent of room. Outside Zone - Protection by ventilation, Type v.
3	Spill containment pit	Reactor Rooms 1, 2 & 3	S	1 - 13	25	0	L	A	Low	Poor	1	*	*	SK03, SK05 & SK06	*Extent of pit: 0.45m x 3m x 0.46m deep.
4	Exhaust Fan Flue Discharges	Reactor Rooms 1, 2 & 3	S	1 - 14	25	0.06	L, G	A	Medium	Good	2	*	*	SK05 & SK06	*Sphere of radius 3m from exhaust fan flue discharge.
5	Flow Reactors	Ventilated Cabinets	S	1 - 13	220	4200	L	A	Medium	Good	2	0.3*	**	SK03, SK04 & SK05	*Above floor. **Extent of ventilated cabinet. Outside Zone - Protection by ventilation, Type v.
6	Flow Reactors	Ventilated Cabinets	S	14	25	3000	G	A	Medium	Good	*	*	*	SK03, SK04 & SK05	*Extent of ventilated cabinet - Protection by ventilation, Type v.
7	Chemical spill	General Laboratory	S	1 - 13	25	0	L	A	Medium	Good	2	0.3*	**	SK04, SK05 & SK06	*Above floor. **Extent of laboratory.
8	Spill containment drain trench	General Laboratory	S	1 - 13	25	0	L	A	Low	Poor	1	*	*	SK03, SK04 & SK06	*Extent of drain trench.
9	Duct leak	Exhaust Fan Room	S	1 - 14	25	0.20	L, G	A	Medium	Good	*	*	*	SK02 & SK05	*Protection by ventilation, Type v.
10	Exhaust Fan Flue Discharges	Ventilated Cabinets & Fume Cupboards	S	1 - 14	25	0.06	L, G	A	Medium	Good	2	*	*	SK04, SK05 & SK06	*Sphere of radius 3m from exhaust fan flue discharge.
11	Chemical experiment or spill	Fume Cupboards	S	1 - 13	25	0	L	A	Medium	Good	NH*	*	*	SK03, SK04 & SK05	*Non-hazardous subject to fume cupboards being fully compliant with AS/NZS 2243.8.

Table C.2 – EXAMPLE of Hazardous area classification data sheet – Part II: List of sources of release

Sheet: 1/1

Plant: Flammable liquid & gas process plant Area: Reactor Rooms, Ventilated Cabinets, General Laboratory, Exhaust Fan Room. Chemical Store. DGs Spill Containment Tank.													Reference drawings: Hazardous Area Zone Diagrams		
1	2	3	4	5	6	7	8			9	10	11	12	13	
Source of release			Flammable material				Hazardous area								
No.	Description	Location	Grade of release ^a	Reference ^b	Operating temperature and pressure ^[1]		State ^c	Ventilation			Zone type 0-1-2	Zone extent ^m		Reference	Any other relevant information and remarks
					°C	kPa		Type ^d	Degree ^e	Availability ^e		Vertical	Horizontal		
12	Leak/spill from stored chemicals	Flammable Liquids Storage Cabinet	S	1 - 13	25	0	L	A	Low	Poor	1	*	*	ZA.5.2.3(c) AS/NZS 60079.10.1	*Interior of flammable liquids storage cabinet.
13	Leak/spill from stored chemicals	Flammable Liquids Storage Cabinet	S	1 - 13	25	0	L	A	Medium	Good	2	1*	3*	ZA.5.2.3(c) AS/NZS 60079.10.1	*Exterior of flammable liquids storage cabinet.
14	Gas Leak	Gas Cylinder Store	S	14	25	13700	G	A	Medium	Good	2	*	*	SK01	*Extent of gas store.
15	Chemical spill	Bldg 208 - DGs Store	S	1 - 13	25	0	L	A	Medium	Good	2	*	*	SK07	*Extent of DGs store.
16	Spill containment pit	Bldg 208 - DGs Stores	S	1 - 13	25	0	L	A	Low	Poor	1	*	*	SK07	*Extent of pit: 3m x 1m x 0.5m deep.
17	Exhaust Fan Flue Discharge	Bldg 208 - DGs Stores	S	1 - 13	25	0.06	L	A	Medium	Good	2	*	*	SK07	*Sphere of radius 3m from exhaust fan flue discharge.
18	Inlet & Exhaust ducts	Bldg 208 - DGs Stores	S	1 - 13	25	0.20	L	A	Medium	Good	2	*	*	SK07	*Interior of inlet & exhaust ducts. Refer Figure ZA.36, AS/NZS 60079.10.1.
19	Vent Outlet	DGs Spill Containment Tank.	S	1 - 13	25	0	L	N	Medium	Good	2	*	*	SK07	*Sphere of radius 1.5m from vent outlet.
20	Underground Collection pits	East of Bldg 206 & 208	S	1 - 13	25	0	L	A	Low	Poor	1	*	*	SK07 & SK08	*Extent of pit.
21	Underground Collection pits	East of Bldg 206 & 208	S	1 - 13	25	0	L	A	Medium	Good	2	*	*	SK07 & SK08	*Above pit opening from ground level: 0.3m vertically and 0.5m horizontally.
22	Vent Pipe	From Underground Collection pits	S	1 - 13	25	0	L	N	Low	Poor	1	*	*	SK07 & SK08	*Interior of vent pipe.
23	Vent Outlet	From Underground Collection pits	S	1 - 13	25	0	L	A	Medium	Good	2	*	*	SK07 & SK08	*Elongated hemisphere of horizontal radius 0.5m from vent outlet and 0.3m high.
24	Interior of Tank - Air/vapour space	DGs Spill Containment Tank.	S	1 - 13	25	0	L	N	Low	Poor	1	*	*	SK07	*Interior of Tank - Extent of air/vapour space.
25	Dip point, hatch etc.	DGs Spill Containment Tank.	S	1 - 13	25	0	L	N	Medium	Good	2	*	*	SK07	*Hemisphere of radius 0.5m from dip point, hatch etc. (For large openings, e.g. man holes, measured from edge of opening).

^a C – Continuous; S – Secondary; P – Primary.

^b Quote the number of list in Part I.

^c G – Gas (Flammable); L – Liquid (Flammable Vapour); LG – Liquefied gas; S – Solid.

^d N – Natural; A – Artificial.

^e See AS/NZS 60079.10.1 Annex B.

^[1] Maximum values from PFDs unless at ambient T & P. Gauge pressure.

Figure 7 – Examples of typical Hazardous Area Drawings

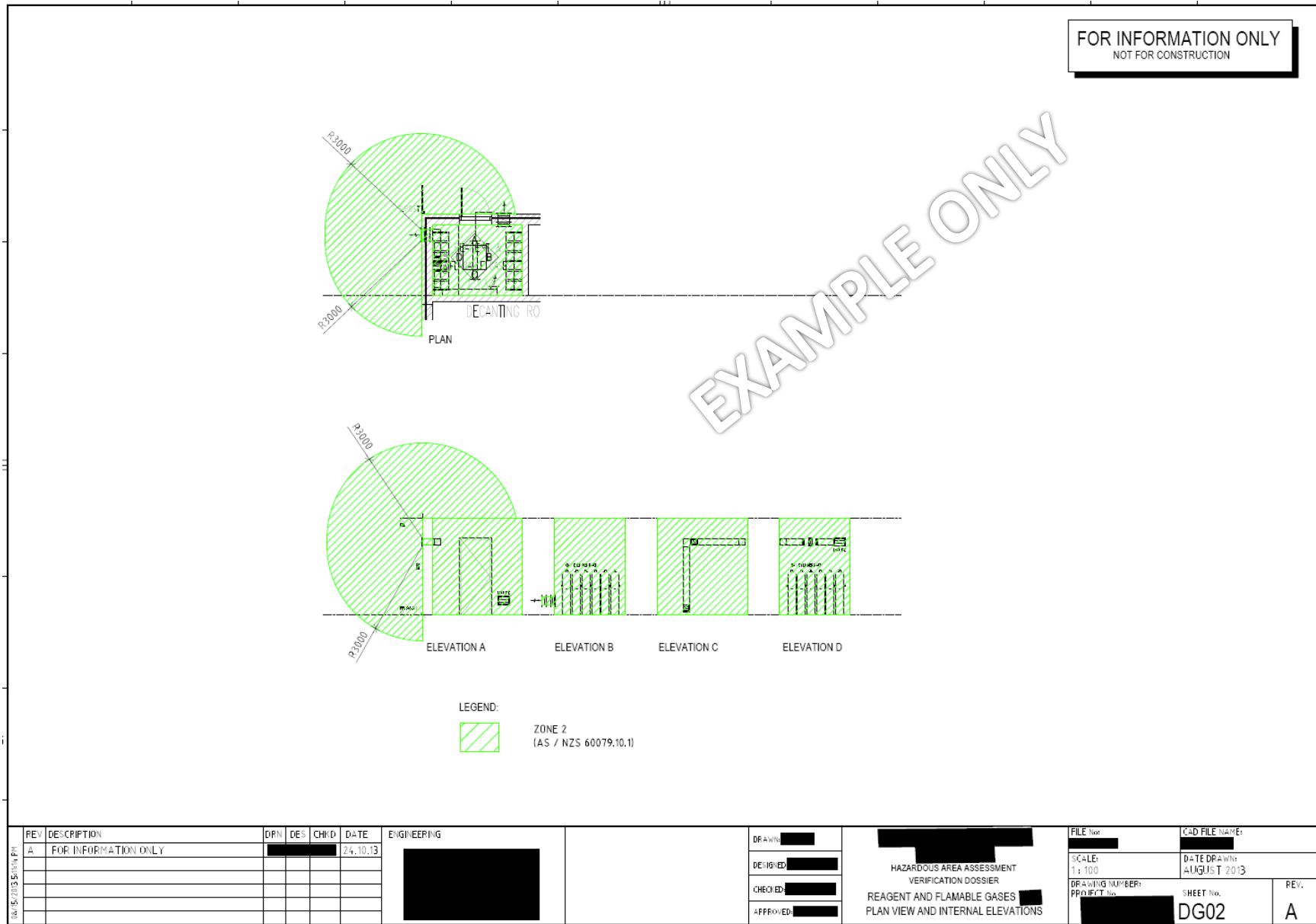

FOR INFORMATION ONLY
NOT FOR CONSTRUCTION

EXAMPLE ONLY

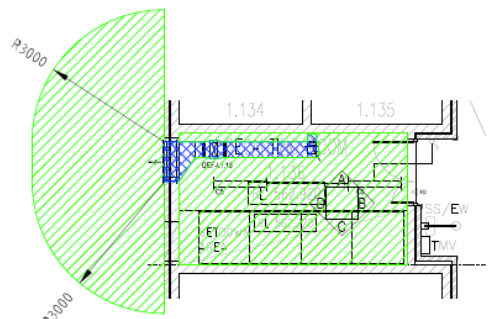

PLAN - HIGH LEVEL ZONING >1 METRE ABOVE TOP OF PACKAGE

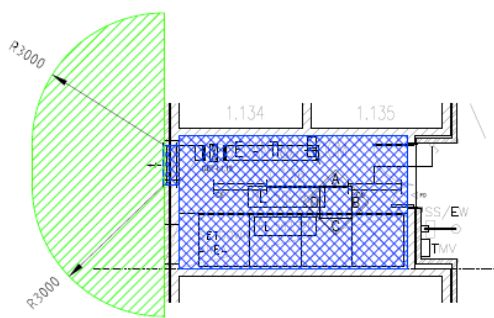

PLAN - LOW LEVEL ZONING <=1 METRE ABOVE TOP OF PACKAGE

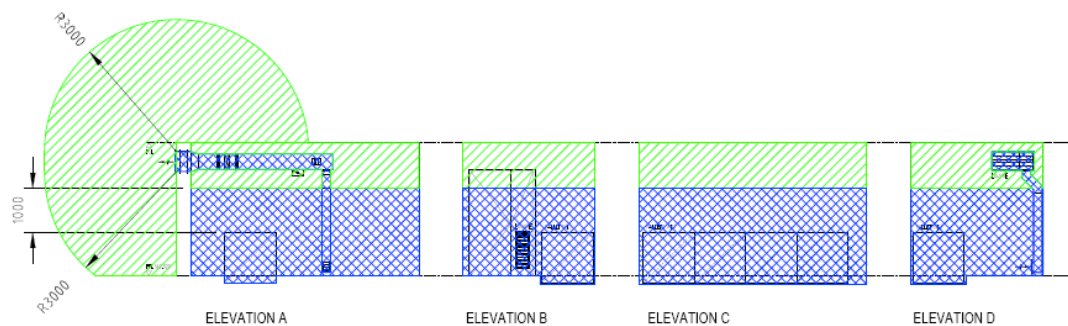



ELEVATION A

ELEVATION B

ELEVATION C

ELEVATION D

LEGEND:

-  ZONE 1
(AS / NZS 60079.10.1)
-  ZONE 2
(AS / NZS 60079.10.1)

REV	DESCRIPTION	DRN	DES	CHKD	DATE	ENGINEERING	DRAWN	DESIGNED	CHECKED	APPROVED	HAZARDOUS AREA ASSESSMENT VERIFICATION DOSSIER DECANTING ROOM	FILE No.	CAD FILE NAME:
A	FOR INFORMATION ONLY				24.10.13						HAZARDOUS AREA ASSESSMENT VERIFICATION DOSSIER DECANTING ROOM	SCALE: 1:100	DATE DRAWN: AUGUST 2013
											PLAN VIEW AND INTERNAL ELEVATIONS	DRAWING NUMBER: PROJECT No.	SHEET No. REV.
												DG04	A

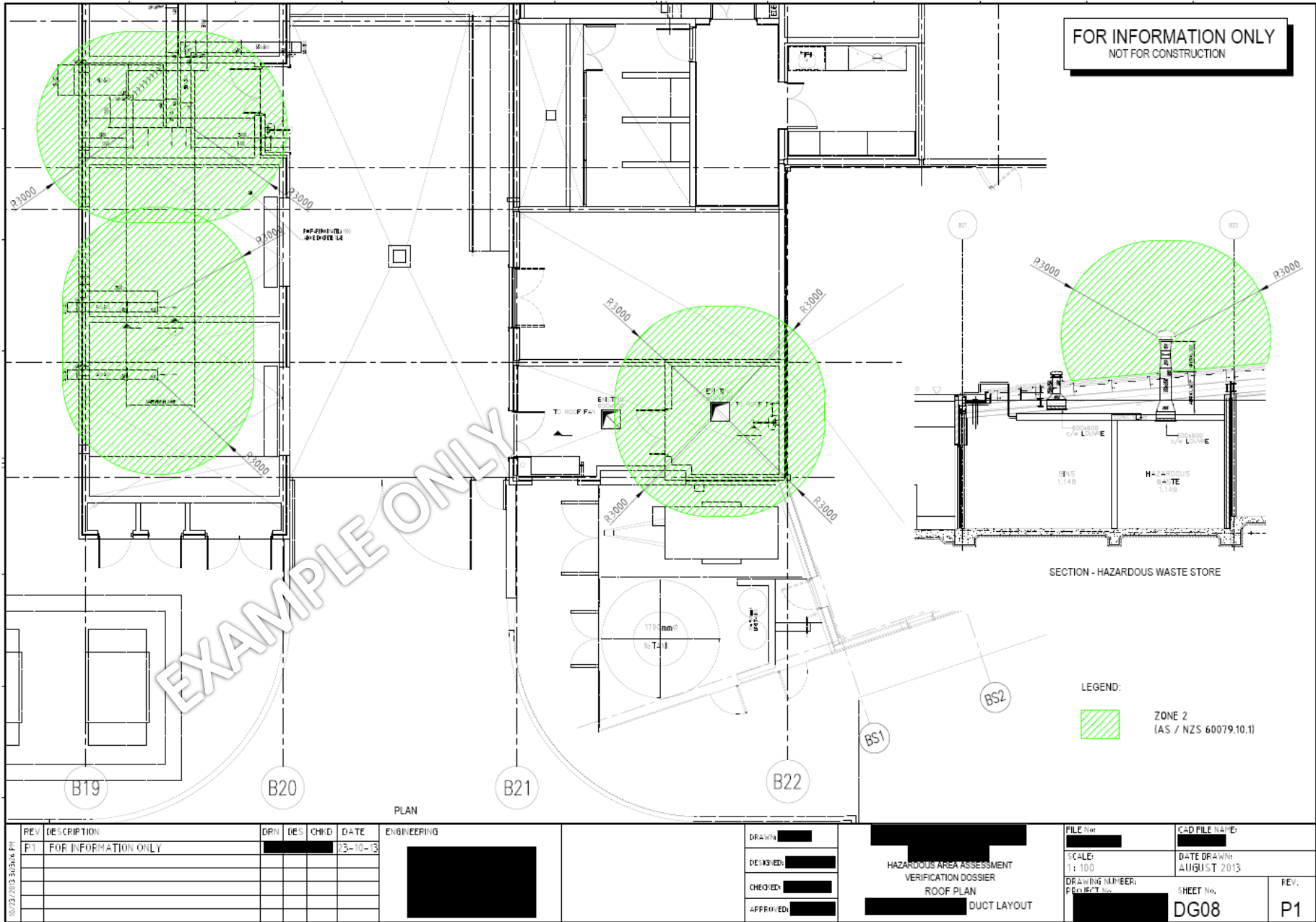

EXAMPLE ONLY

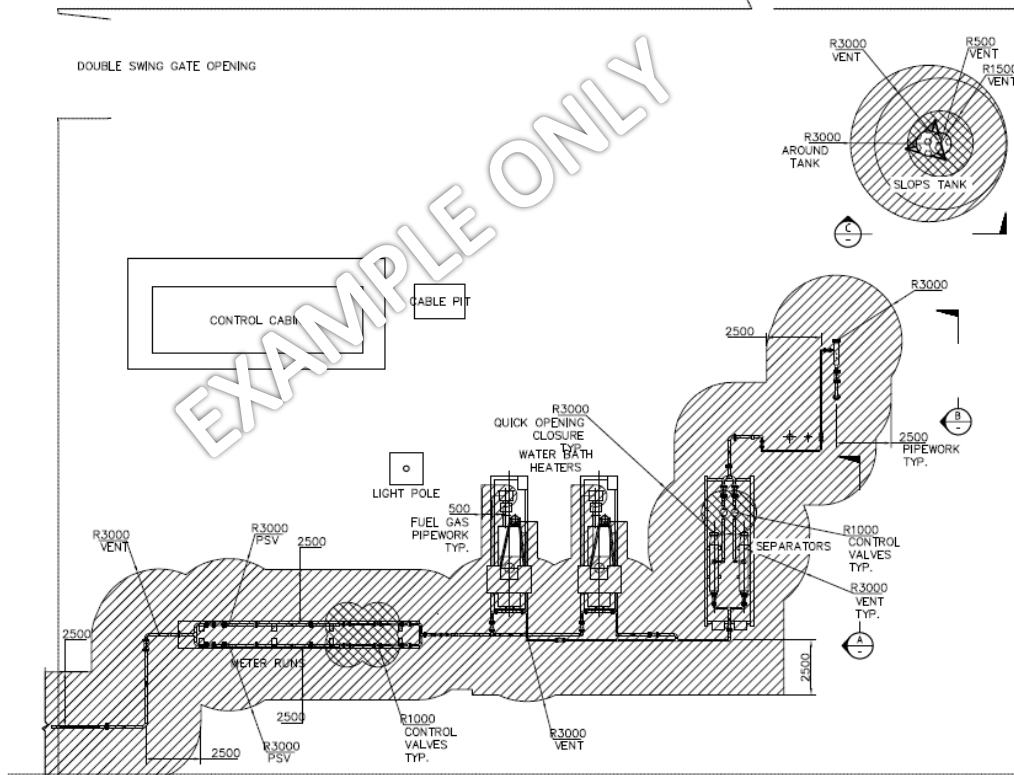

PLAN VIEW (A)
SCALE 1:100

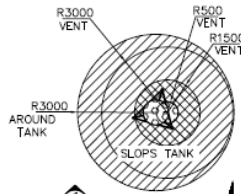

(C)

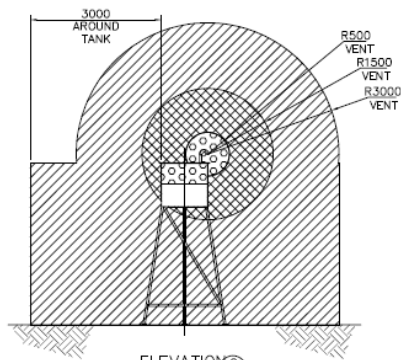

ELEVATION (C)
SCALE 1:50

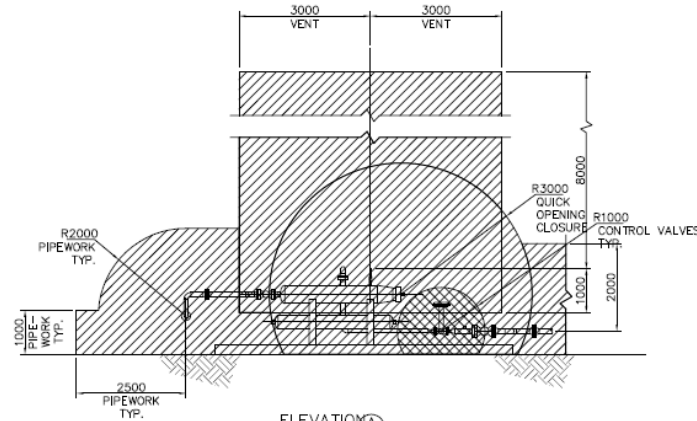

ELEVATION (A)
SCALE 1:50

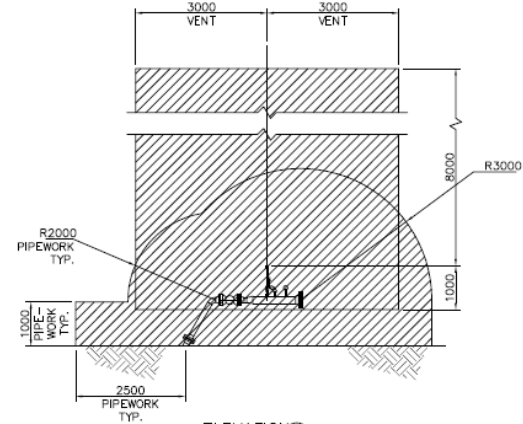

ELEVATION (B)
SCALE 1:50

CLASSIFICATION LEGEND

Zone 0

Zone 1

Zone 2

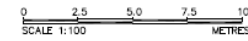
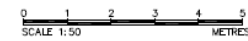

GAS IIA
LIQUIDS IIA
T1

HAZARDOUS AREA
METRO STATION

Table with 3 columns: NO., REVISION, and DATE.

1. ALL BELOW GRADE PIPING AND EQUIPMENT NOT SHOWN FOR CLARITY OF DRAWINGS

Table with 12 columns: NO., NAME, DATE, SCALE, SHEET NO., TOTAL SHEETS, DRAWN BY, CHECKED BY, DESIGNED BY, APPROVED BY, PROJECT NO., and CONTRACT NO.

Figure 8 – Closed vessel hazardous areas – Example Fig. D.4.2.3 from AS/NZS IEC 60079.10.1 Sup 1:2022 Appendix D

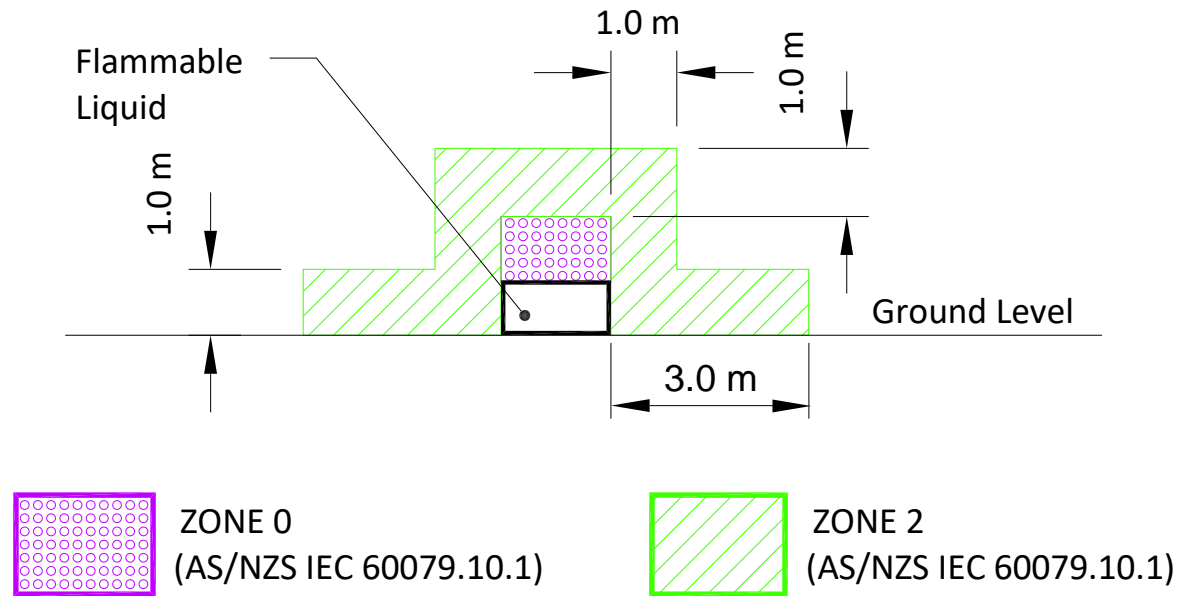

Figure D.4.2.3
Closed vessel, up to 20 L
Batch type processes



Figure 9 - Example of a CSIRO Area Hazard Poster containing the hazardous area signage



HAZARDS

in this Work Area





WARNING: HAZARDOUS AREA

There is an explosive atmosphere risk in this space:
Flammable gas cylinders and attached apparatus.
 The type of hazardous area is: *Zone 1 and Zone 2*
 Equipment installed in this room may be hazardous area rated.
 For further information refer to the Hazardous Area Verification Dossier located at:
Top Drawer of cabinet immediately to the left of the door.

Precautionary Measures Required







Building 004 – Ex Building Room 101 – Gas lab	Name	Out of Hours Contact Number
Area Custodian	A. Custodian	(00) 4272 7476
Other	B. Custodian	(00) 6253 7233

Last updated: 17 August 2021

Example of Hazardous Area Risk Assessment

Scope

This example of a hazardous area risk assessment provides guidance on the appropriate hazardous zone surrounding chemical storage cabinets containing “flammable chemicals” (Classes 3, 4.3, 5.1 and 5.2 dangerous goods or those with a subsidiary risk of Class 3). The assessment is limited to a typical laboratory situation and applies to a *laboratory room* enclosed by bounding walls that may be part of a larger laboratory containing other laboratory rooms.

Chemical Storage Cabinets – Hazardous Zones

Australian Standard’s Requirements

The following edited excerpts from the relevant Australian Standard’s summarise the hazardous area requirements applying to chemical storage cabinets in a laboratory when they contain chemicals that may lead to the formation of a hazardous area.

The Safety in laboratories standard AS 2243.2:2021 – Part 2: Chemical aspects and storage, states that where flammable vapours may be present as part of normal or abnormal operations, the areas shall be classified in accordance with AS/NZS IEC 60079.10.1. AS 2243.2, Clause 6.3.4 also states that cabinets shall be constructed in accordance with AS 1940.

The Explosive atmospheres standard AS/NZS 60079.10.1-2009 - Classification of areas - Explosive gas atmospheres Supplement 1 Appendix F, Clause F.1.2 states that a laboratory may be considered non-hazardous if it meets the criteria of Clause F.1.1. These criteria include container sizes of flammable liquids being limited to ≤ 1 L, or ≤ 2.5 L in spill-proof containers; spill control measures such as bunded tubs and spill clean-up processes and equipment are in use; adequate ventilation to mitigate these small volumes creating a hazardous vapour cloud; and that there are procedural controls in place to minimize the total quantities of flammable liquids present.

The Explosive atmospheres standard AS/NZS 60079.10.1-2009 - Classification of areas - Explosive gas atmospheres Supplement 1 Appendix C, Clause C.4.3(c) states that for the storage of small (≤ 20 L) containers, storage cabinets as defined by AS 1940, irrespective of the ventilation of the storage area:

- (i) The interior of the cabinet is a Zone 1 hazardous area;
- (ii) For cabinets that contain packages which are always closed, the exterior of the cabinet together with any vent provided on the cabinet, from ground level to 0.5 m above and 0.5 m laterally shall be a Zone 2 hazardous area;
- (iii) For cabinets which contain closed packages >500 mL for occasional decanting, the exterior of the cabinet together with any vent provided on the cabinet, from ground level to 0.5 m above and 1 m laterally shall be a Zone 2 hazardous area;
- (iv) The area within 0.5 m above the floor and 3 m forward laterally from the cabinet shall be a Zone 2 hazardous area to account for minor spills which may occur while handling flammable liquids.

The storage and handling of flammable and combustible liquids standard AS 1940:2017, Clause 4.9.7 states that where flammable liquids are stored, ignition sources shall be excluded from the area outside the cabinet to a distance of 3 m measured laterally, and from floor level to a height of 1 m above any opening in the cabinet, including the door, **or a distance determined in accordance with AS/NZS 60079.10.1.**

Table 6: Threshold for being considered “small” quantities –AS/NZS 60079.10.1 Supp. 1 Appendix C

Flammable Liquid Storage Quantity in <i>Laboratory Room</i>
100 L or kg in containers that remain unopened;
25 L or kg for infrequent decanting purposes;
5 L or kg in open containers that may be opened for regular use

AS/NZS 60079.10.1 Supplement 1 Appendix C limits the scope of its examples of hazardous area classification for flammable liquids by stating that the classifications given are not representative examples of the storage and use of flammable liquids for quantities exceeding the above (Table 6). Note - these *small quantities* are almost identical to the quantities listed in AS 1940 Clause 2.3.3, and as 60079.10.1 was updated more recently, we will use these quantities.

All chemicals must be in closed containers when stored in a chemical storage cabinet.

Risk Assessment

Based on the provisions of the Australian Standards discussed above, it is reasonable to assess the level of hazardous area risk relating to a chemical storage cabinet on the basis of whether the quantity of flammable chemicals stored are less, or more than, the *small quantities* listed above. The *small quantities* are considered to include all the flammable liquids stored and used within the *laboratory room*.

The risk can therefore be considered lower for situations where the quantity of flammable chemicals contained in the *laboratory room* are less than or equal to the *small quantities*, especially where some or all criteria for excluding a laboratory from being a hazardous area are met (see above regarding Appendix F of the Supplement to the Standard).

Although the risk will be lower, it will not be eliminated and it is therefore necessary to apply a minimum level of hazardous zoning to these chemical storage cabinets. The rationale for adopting this minimum hazardous zone around flammable chemical storage cabinets, even though only up to *small quantities* are stored, is supported by AS 1940 which states in Clause 2.3.3 that:

“There shall be no uncontrolled sources of ignition in any space in which a flammable mixture of vapour and air could be present.

WARNING: EVEN SMALL QUANTITIES OF FLAMMABLE LIQUID, IF SPILT, CAN CREATE A VAPOUR CLOUD THAT CAN TRAVEL CONSIDERABLE DISTANCES AND FLASHBACK.”

and; AS/NZS 60079.10.1 Supplement 1 which notes in Clause C.1 that:

“Under some circumstances, particularly in confined spaces, caution should be taken with small quantities of flammable liquids as these may give rise to hazardous areas.”

In this assessment we consider:

- (a) Whether some or all risk control measures are in place within the laboratory (see the criteria listed in AS/NZS IEC 60079.10.1 Supp.1 Appendix F)
- (b) Whether the quantities in the flammable liquid cabinet are less than those considered *small* quantities (see Table 6)
- (c) Whether the types and quantities of flammable liquids warrant special precautions despite being below the threshold quantities considered small (e.g. PG I flammable liquids).

Clause C.4.3(b) of AS/NZS IEC 60079.10.1 Supplement 1 requires that ignition sources must be at least 300 mm distant from flammable liquids packages (cabinets in this case). Within this distance a Zone 2 hazardous area exists. This zone also extends 300 mm above the floor of the rest of the *laboratory room*, where not all criteria listed in Appendix F of Supp. 1 are met.

For quantities greater than the *small quantities*, the prescriptive requirements of Clause C.4.3(c) will apply, provided all requirements are met (e.g. container size within cabinet). Where we identify that the quantities, container sizes or types of flammable liquids pose a higher risk of a flammable or explosive atmosphere forming, the 3 m exclusion zone referred to in AS 1940 must be considered.

Summary of Hazardous Areas

In this example summary, the hazardous areas applying to flammable chemical cabinets in the *laboratory room* can be defined by the relative risk, as shown in the table below.

Table 7: Hazardous Area - Flammable Chemical Storage Cabinets

Flammable Chemical Storage Quantity in <i>Laboratory Room</i> (L or kg)	Extent of Hazardous Area
<u>Up to</u> threshold of small quantities	Zone 1 – Interior Zone 2 – Exterior 300 mm from all sides.
<u>Over</u> threshold of small quantities, but containers remain unopened, or are limited to 500 mL	Zone 1 – Interior Zone 2 – Exterior 0.5 m above and laterally around the cabinet. Additionally, 3 m laterally from the front of the cabinet to a height of 0.5 m.
<u>Over</u> threshold of small quantities and containers >500 mL which are opened occasionally for decanting	Zone 1 – Interior Zone 2 – Exterior 0.5 m above the cabinet and 1 m laterally around the cabinet. Additionally, 3 m laterally from the front of the cabinet to a height of 0.5 m.
<u>Over</u> threshold of small quantities and higher risks identified, such as containers >20 L; PG I flammable liquids >500 mL	Zone 1 – Interior Zone 2 – Exterior 3 m laterally, and from floor level to a height of 1 m above any opening in the cabinet, including the door ⁵ .

The above requirements are illustrated, respectively, in Figures 10-13 below. Note in all these cases, the laboratory floor has been retained as a hazardous area to a height of 300 mm as it has been determined containers >1 L will be held.

⁵ Note that were only flammable chemicals that have vapour densities heavier than air are stored in the cabinet, the 1 metre height above the openings in the cabinet may be measured from the floor, subject to a further risk assessment of this concession which takes into account the height of the cabinet and other relevant considerations.

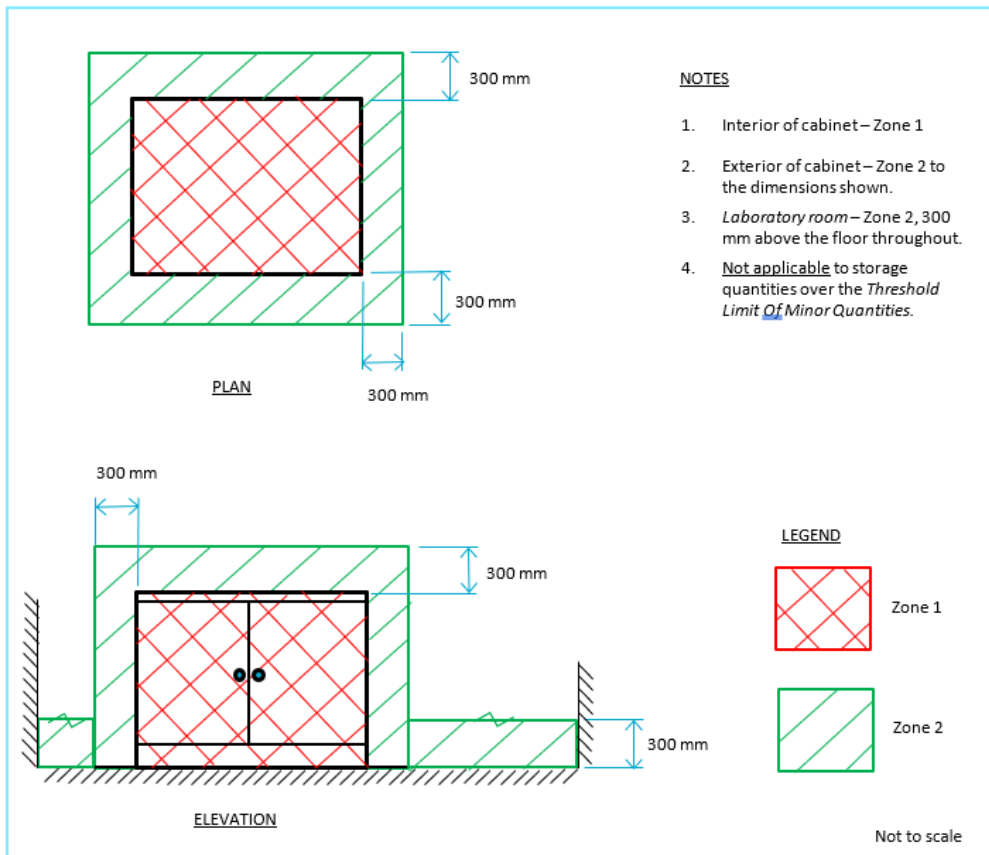

Figure 10. Chemical Storage Cabinet Hazardous Areas – Up to threshold of small quantities

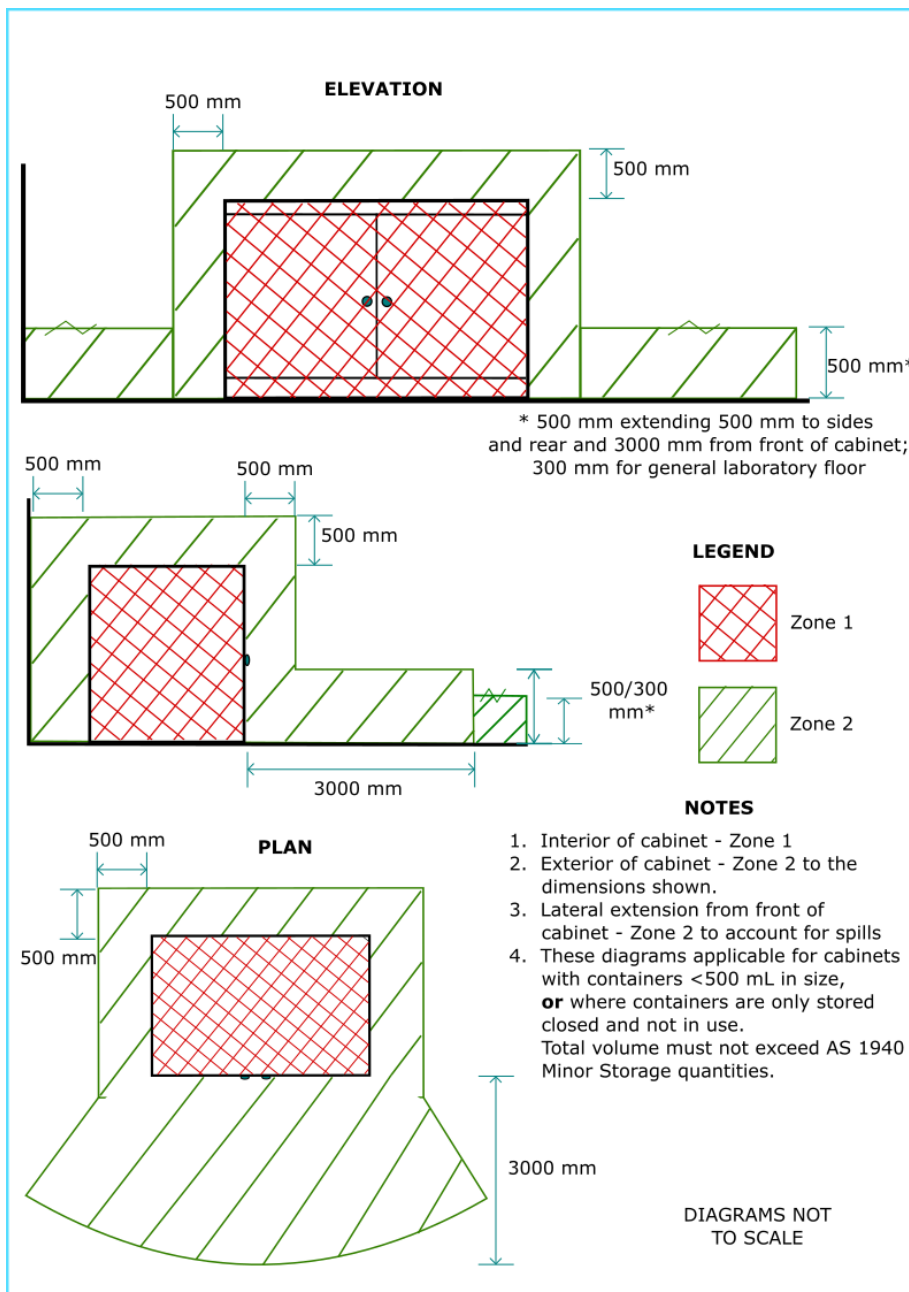

Figure 11. Chemical Storage Cabinet Hazardous Areas – Containers <500 mL or only unopened containers

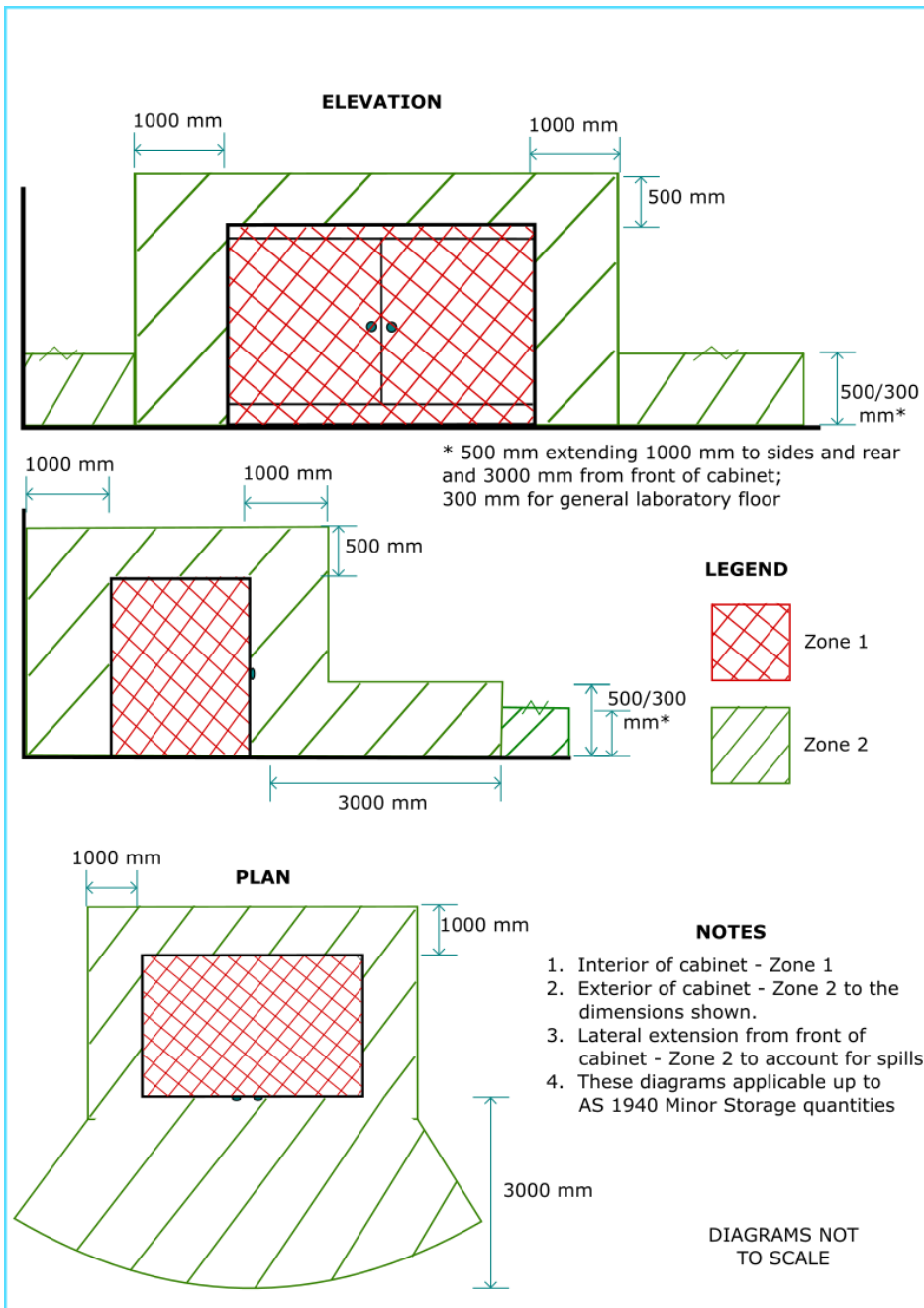

Figure 12. Chemical Storage Cabinet Hazardous Areas – Containers < 20 L and not high risk flammable liquids.

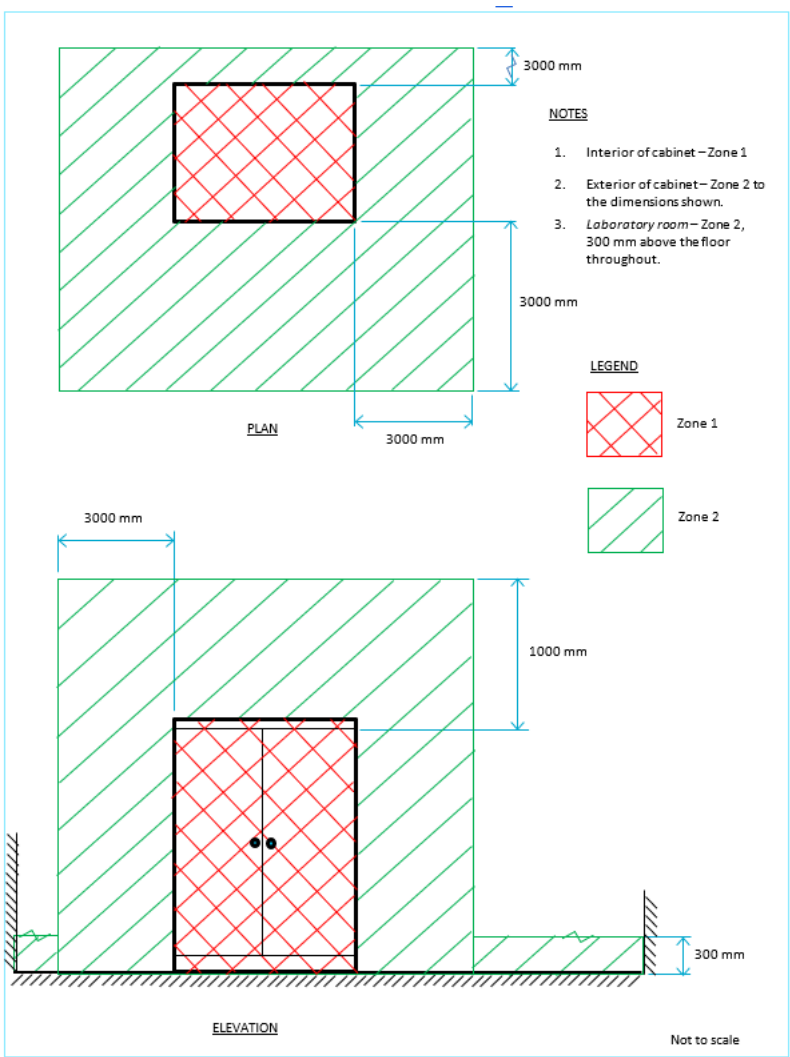

Figure 13. Chemical Storage Cabinet Hazardous Areas – Large containers or high risk flammable liquids

Glossary

Combustible	With respect to hazardous areas, combustible may refer to combustible dusts and combustible liquid vapours which can form a potentially explosive atmosphere.
Combustible dust	Dusts which are combustible or ignitable in mixtures with air. These may include dust, fibres and flyings of materials as diverse as grain, sugar, wood, starch, coal, aluminium, and polypropylene, etc.
Combustible liquid	Typically any liquid that gives off a flammable vapour and has a flash point $>60^{\circ}\text{C}$.
Ex	An abbreviation for <i>Explosion</i> and used as a prefix denoting explosion protected.
Ex rated equipment	Explosion protected equipment using one or more techniques so that the equipment is suitable for use in a specified hazardous area.
Explosive atmosphere	A mixture with air, under atmospheric conditions, of flammable substances in the form of gas, vapour or dust, which, after ignition, permits self-sustaining propagation. For flammable gases and vapours, the mixture with air needs to be between the upper and lower explosive limits to form an explosive atmosphere.
Firedamp	Methane, especially as forming an explosive mixture with air in coal mines.
Flammable	With respect to hazardous areas, flammable may refer to flammable liquid vapours, flammable gases, and flammable solids that give off flammable vapours, that can form a potentially explosive atmosphere.
Flammable liquid	Typically any liquid that gives off a flammable vapour and has a flash point $\leq 60^{\circ}\text{C}$.
Flash point	The lowest temperature, at atmospheric pressure, at which application of a test flame causes the vapour of the test portion to ignite under the specified conditions of test (typically a closed-cup test, refer to <i>AS/NZS 2106 Methods for the determination of the flash point of flammable liquids (closed cup) series</i>).

Group classification	Classification system of equipment related to the explosive atmosphere for which the equipment is intended to be used, e.g. Group II:- all places with an explosive gas atmosphere other than mines susceptible to fire damp.
Hazardous area	An area in which an explosive atmosphere is present, or may be expected to be present, in quantities such as to require special precautions for the construction, installation and use of equipment.
Lower Explosive Limit (LEL)	Also known as Lower Flammable Limit (LFL). The concentration of flammable gas, vapour or mist in air, below which an explosive atmosphere will not be formed.
Pyrophoric substance	A substance that ignites spontaneously on exposure to air (e.g., phosphorus, silane gas) or water (e.g., potassium or sodium).
Source of release	A point or location from which a gas, vapour, mist or liquid may be released into the atmosphere so that an explosive gas atmosphere could be formed.
Temperature classification	A classification system of Ex equipment, based on its maximum surface temperature, related to the specific explosive gas atmosphere for which it is intended to be used.
Upper Explosive Limit (UEL)	Also known as Upper Flammable Limit (UFL). The concentration of flammable gas, vapour or mist in air, above which an explosive atmosphere will not be formed.
Zone	Hazardous areas are classified into hazardous Zones based upon the frequency of the occurrence and duration of an explosive gas atmosphere. (Refer to Appendix A herein for a description of the different zones).

